

# SLICK SLEUTH OIL SPILL MONITOR SS100EXd

Installation, Operation, and Maintenance Manual  
Revision B

REFERENCE ONLY



InterOcean Systems, LLC  
9201 Isaac Street, Suite C  
Santee, CA 92071

Copyright© 2022 by InterOcean Systems, LLC. All rights reserved.

The information in this manual is furnished for informational use only and is subject to change without notice. InterOcean Systems, LLC assumes no responsibility or liability for any errors or inaccuracies that may appear in this book.

Printed in the United States of America

Written and designed at InterOcean Systems, LLC  
9201 Isaac Street, Suite C  
Santee, CA 92071  
USA

InterOcean systems, LLC  
Telephone: (858) 565-8400  
Fax: (858) 258-4850  
E-Mail: sales@interoceansystems.com

Operation and Maintenance Manual Part Number 473586014900 (REV B)

APPROVED BY:                     *Stu W. Van Rith*                          DATE:                     9/13/2022

## TABLE OF CONTENTS

1	DESCRIPTION.....	1
	SPECIFICATIONS .....	1
2	INSTALLATION.....	3
2.1	UNPACKING.....	3
2.2	MECHANICAL.....	3
2.3	ELECTRICAL .....	3
2.4	INITIALIZATION.....	6
3	OPERATION .....	8
3.1	REPORTING.....	8
3.2	SETUP .....	10
4	MAINTENANCE .....	13
4.1	PREVENTATIVE MAINTENANCE .....	13
4.2	LAMP REPLACEMENT .....	13
4.3	TROUBLESHOOTING .....	13
4.4	RECOMMENDED SPARES .....	14
5	DRAWINGS .....	15
	INSTALLATION DRAWING .....	16
	QUICK START INSTRUCTIONS	
	HARARDOUS LOCATION INSTALLATION	
	APPENDIX A	
	SLICK SLEUTH UTILITY PROGRAM	
	APPENDIX B	
	THEORY OF OPERATION	
	APPENDIX C	
	EXTERNAL SERIAL COMMUNICATIONS INTERFACE	
	APPENDIX D	
	SERIAL COMMUNICATIONS PROTOCOL SLICK SLEUTH	
	APPENDIX E	
	PREVENTATIVE MAINTENANCE	
	APPENDIX F	
	SLICK SLEUTH LAMP REPLACEMENT	
	APPENDIX G	
	USB DRIVER INSTALLATION	
	APPENDIX H	
	RS485	

**1 DESCRIPTION**

The Slick Sleuth Oil Spill Monitor (OSM) is a remote sensing device for the detection of oil pollution on a surface. It detects oil by stimulating fluorescence in the oil and then detecting the fluorescence. A short burst of collimated UV light is directed onto the surface. The resulting fluorescence is filtered and detected by a focused optical system.

The Oil Spill Monitor is enclosed in a NEMA 4X (IP66) enclosure to provide water-tight integrity and reliability. External power is provided to the Oil Spill Monitor via a cable through a conduit port. A second cable provides communication to the user’s equipment.

The Oil Spill Monitor makes periodic detections and reports the results through the communication cable on a pre-set period. The period is pre-set at IOS but may be changed by the user through an internal USB serial port.

**NOTE**  
If the Oil Spill Monitor is to be installed in a hazardous location, the instructions and information in the Hazardous Location Installation document in Section 5 must be adhered to.

**SPECIFICATIONS**

Input Power, AC	
Input Voltage	85-264 VAC
Input Frequency	50/60 Hz
Input Current	0.2/0.1 amp typ. (115/230 VAC)
Inrush Current	15/30 A max. (115/230 VAC)
Input Power, DC	
Input Voltage	+20 VDC to +28 VDC
Input Current (24V in)	150 milliamps average 1.25A peak

**NOTE**  
Input current is dependent on operating setup. Values listed as “average” represent a 5 second period with 10 pulses/sample.

Operating Temperature

Range	-10°C to +60°C
Weight	10 lb (4.5 kg)
Detection Range:	0.25 – 1.0 meters

Communications Interfaces

Oil Detect and Status Relays

Configuration:	SPST
Rating:	110 VDC/0.3 A – 33 W
	30 VDC/2.0 A – 60 W
	120 VAC/0.5 A – 60 VA
	240 VAC/0.25 A – 60 VA

State:

Oil detect

No Detect	Open
Detect	Closed

Equipment Status

Normal	Closed
Fault	Open

0-20ma Current Loop

Source Mode	
Compliance:	0 - 650 ohms

Serial Communications (local access)

USB

Serial Communications

RS485, 4-wire  
RS485, 2-wire

Hazardous Location Rating

See Drawing No. 735861342 in Section 5

---

## 2 INSTALLATION

### 2.1 UNPACKING

Upon receiving the Oil Spill Monitor inspect for external signs of shipping damage. If shipping damage has occurred, immediately file a claim with the carrier and contact InterOcean Systems.

#### NOTE

Step-by-step instructions to perform the installation and initialization of the Slick Sleuth OSM are provided in the Slick Sleuth OSM Quick Start Instructions in Section 5 to assist the first-time user. The installation information that follows in Section 2 is provided for the experienced user and is referenced where appropriate from the Quick Start instructions.

A software utility program is available to facilitate installation and maintenance. IOS strongly recommends that the user obtain a copy of the program for use during installation. The procedure in the Quick Start Instructions have been developed based on the use of the utility program. Instructions for the use of the utility program are provided in Appendix A.

### 2.2 MECHANICAL

The Oil Spill Monitor mounts vertically above the surface as shown in the Installation drawing in Section 5. The area beneath the Oil Spill Monitor, depicted as a cone in the Installation drawing, must be clear of all obstructions to allow the full surface to be illuminated.

Mounting to the user platform is done using four tapped holes in the boss as shown on the Installation drawing.

### 2.3 ELECTRICAL

#### 2.3.1 Power

When AC power is provided from an external AC power source the wiring connection is shown in Figure 2.3-1. IOS recommends that a 3.15A slo blo fuse be used on the input power to the OSM.

When DC power is provided from an external DC power source the wiring connection is shown in Figure 2.3-1. IOS recommends that a 2.0A slo blo fuse be used on the input power to the OSM

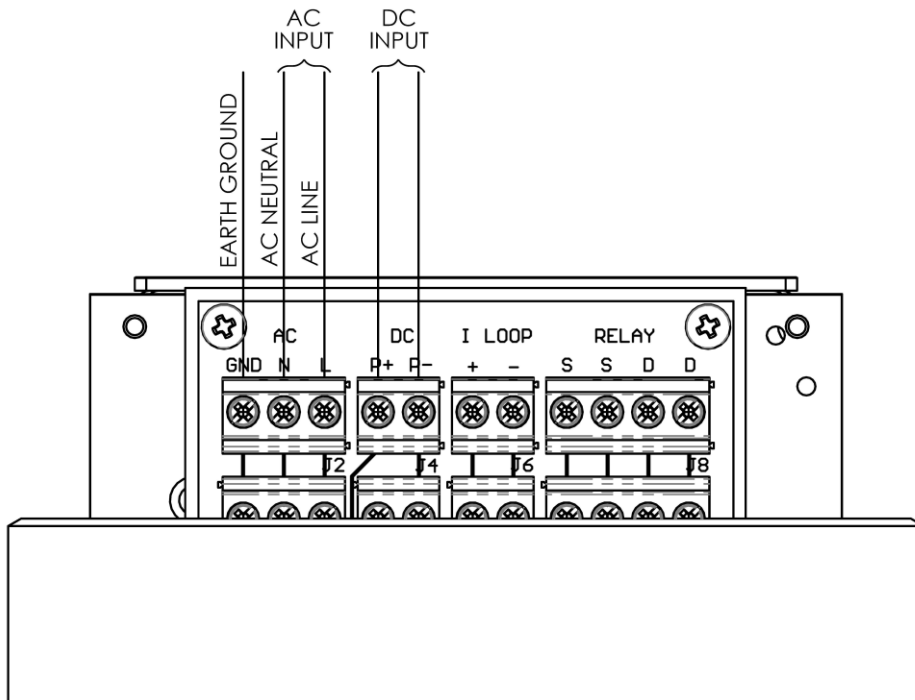

**Figure 2.3-1**  
**Power Wiring**

2.3.2 Interface

For an Oil Spill Monitor using a relay communication interface, the cable to the user's equipment is either a 2-wire cable or a 4-wire cable. The communications cable must meet the requirements of the Installation drawing.

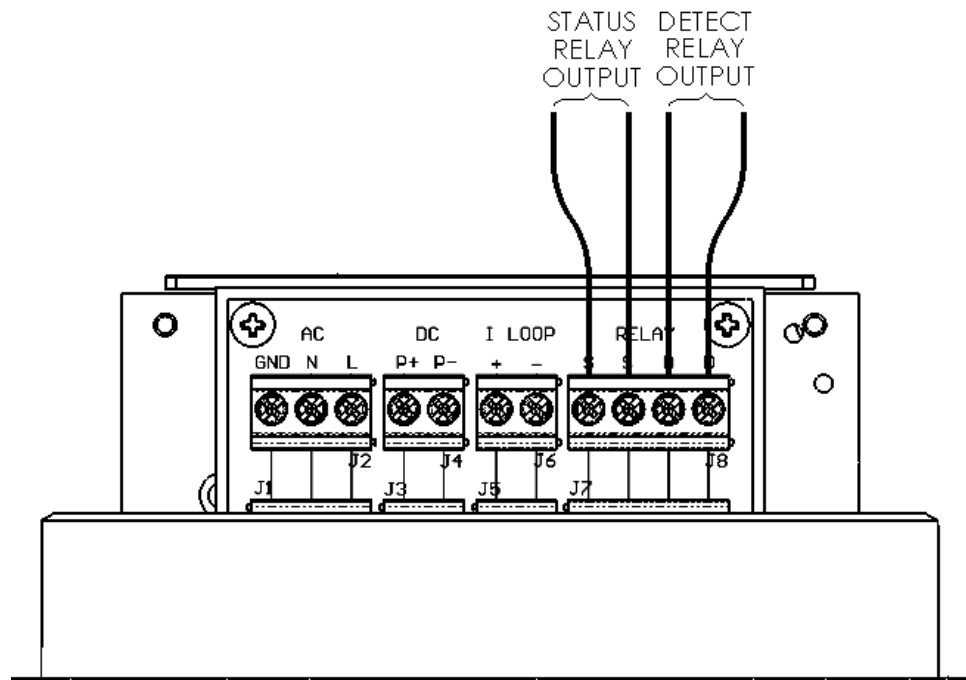

**Figure 2.3-2**  
**Relay Output wiring**

For an Oil Spill Monitor using a current loop communications interface, the communications cable to the user's equipment is a 2-wire 0-20 ma current loop. The wiring connection is shown in Figure 2.3-3. The communications cable must meet the requirements of the Installation drawing.

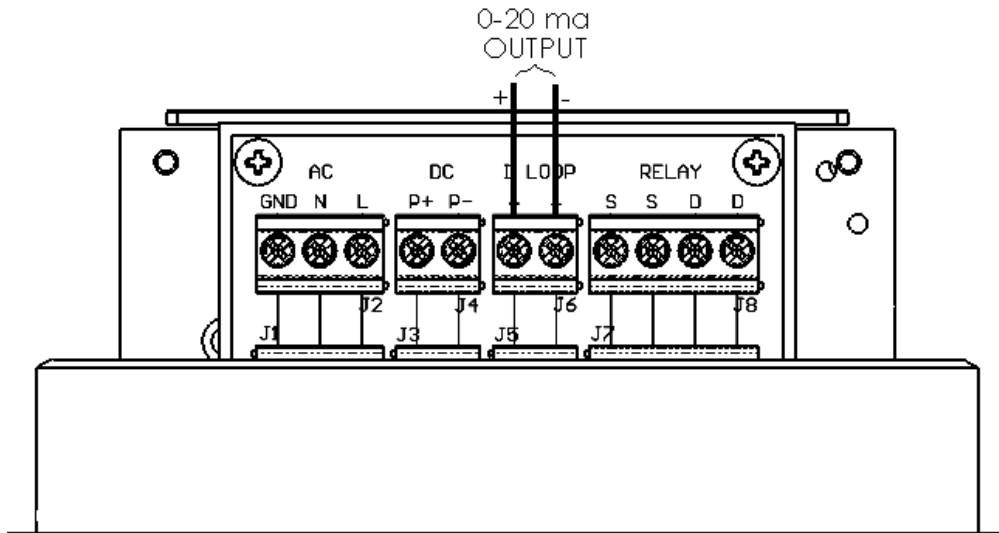

**Figure 2.3-3**  
**0-20ma Current Source Output Wiring**

2.3.3 Serial Interface

For local access, typically for initial setup or periodic maintenance, a USB port is provided under the top cover of the enclosure.

For remote serial interface the RS485 port is used. See Appendix H.

## 2.4 INITIALIZATION

The Oil Spill Monitor is shipped from IOS configured to operate immediately upon application of power. Only one initialization procedure is required to optimize the performance of the Oil Spill Monitor. The procedure directs the Oil Spill Monitor to make measurements to establish the ambient conditions from which the detection threshold is set. This measurement is referred to as a “baseline” measurement.

When making the baseline measurement ensure that no oil pollution or other foreign matter is present below the Oil Spill Monitor as it will bias the measurement. If, however, an oil sheen or some amount of foreign matter is present and is expected to always be present, the baseline should be done to establish the “normal” operating conditions.

### 2.4.1 Quick Initialization

The SS100 may be quickly initialized using the procedures in the Quick Start Instructions in the section titled ‘Quick Setup’. This procedure directs the OSM to make a baseline measurement. This procedure does not require that the SS100 be opened, thus simplifying the process in a hazardous environment. This procedure may be performed at any time to re-establish the baseline for the OSM.

The application of the magnetic activation tool to initiate the ‘Quick Setup’ is illustrated in Figure 2.4-1

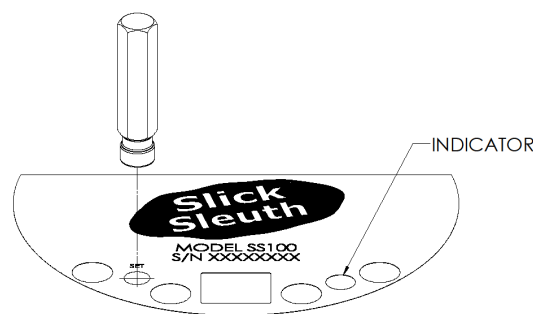

Figure 2.4-1  
Quick Setup

### 2.4.2 Advanced Initialization

When the user needs to manage the OSM in greater detail than just the setting of the baseline, the procedures in the Quick Start Instructions in the section titled 'Advanced Setup' may be followed. The baseline measurement is performed by sending the Baseline '1' command to the OSM. The OSM responds with three count values. The first count, which is identified in the protocol as the average detection count, is the baseline measurement. Record this value for future reference.

In addition to establishing the baseline during the initialization process, other settings may also be adjusted. For example, the offset (detection threshold = baseline + offset) may be increased or decreased according to the users requirements and desired sensitivity. A small offset will make the Oil Spill Monitor sensitive to small amounts of oil but may also increase the probability of false alarms. A large offset will minimize the probability of false alarms but will also increase the amount of oil required to cause a detection. Refer to the Quick Start Instructions in Section 5 and the Theory of Operation in Appendix B for implementation and guidelines.

### 3 OPERATION

#### 3.1 REPORTING

Immediately after power is applied the Oil Spill Monitor begins a periodic detection and reporting cycle at the pre-set period. The period is once every 5 seconds, unless specified otherwise at time of order or changed by the user.

##### 3.1.1 Relay Interface

A single relay contact pair is available. The relay contacts close when oil is detected as “present.” The determination is based upon background and threshold levels established at the factory or by the user during routine setup of the Oil Spill Monitor. The OSM maintains the relay in its state for the last condition reported until the next detection cycle reporting a change in condition. The relay is an SPST relay.

##### 3.1.2 Current Loop Interface

The message transmitted through the current loop interface is formatted in one of the following formats:

###### a. Discrete (Yes/No) Output

Yes/No output means that oil is reported as either detected or not detected. This determination is based upon background and threshold levels established by the user during routine setup of the Oil Spill Monitor. There is also an output level to indicate ‘fault’ status. With the “Yes/No” protocol:

3 mA = Indicates ‘Fault’ (equipment/power system out of specification or faulty)

6 mA = Indicates ‘NO Oil Detected’, & ‘monitor OK’

20 mA = Indicates ‘YES Oil Detected’, & ‘monitor OK’

The Oil Spill Monitor will maintain output level for the last condition reported, until a new condition is detected and reported at the corresponding output level. During normal operation the OSM will set the output at a nominal 6 mA, and hold the output at 6 mA indefinitely or until a change of conditions. If a positive detection decision is made, the output is set to a nominal 20 mA and held at 20 mA until there is no longer oil detected or until a fault occurs. If oil is no longer present the output returns to a nominal 6 mA.

**b. Scaled Output**

Scaled output means that output is scaled proportionally to the signal strength (amount/type) of oil detected. This detection protocol is for users who want the signal to reflect the actual reading or raw number of “counts”. As with both protocols, the monitor maintains output level for the last condition reported until a new condition is detected and reported at the corresponding output level. With the “Scaled Output” protocol:

3 mA = Indicates ‘Fault’ (equipment/power system out of specification or faulty)

4-20 mA = Output is proportional to the fluorescence signal returned from any oil detected – with 4 mA representing ‘No Return’, and 20 mA (minus offsets) representing ‘Full Scale Return’. See Appendix B for a detailed description of the scaling.

**c. Scaled/Corrected Output**

The data format is the same as B) Scaled Output except that the ambient (or background) signal is subtracted from the signal before it is output on the current loop interface. The correction is the baseline measurement made during initialization (Ref. Section 2.4) or as measured by the adaptive baseline, if enabled.

## 3.2 SETUP

The Oil Spill Monitor is setup at the factory and can require a programming change in the field after the unit has been installed and initialized. If setup changes are required, the Oil Spill Monitor must be setup through the serial interface using the Slick Sleuth utility program (ref. Appendix A).

Features affecting performance that the user may wish to change are the following:

### Detection Period

The time interval between periodic reports. Send Command 'P' with the desired time interval (in seconds). Setting the period to less than 5 seconds sets the sample cycle to single sample every 0.5 seconds.

### Number of Samples

The number of flashes used in a detection sequence. Increasing the number of samples improves detection reliability. However, it increases power consumption and decreases flash lamp life. Send Command 'B' with the desired number of flashes. The default number of samples is 10 (maximum allowed).

### Sample Interval

The time interval between flashes in a detection sequence. Send Command 'C' with the desired time interval (100 millisecond steps). The default interval is 01 (100 milliseconds).

### Offset

The threshold for detection. The offset added to the baseline is the counts threshold for detection. This is the sensitivity control. Send command 'T' with the desired offset. The default offset is 30 counts.

Detection occurs when the measured signal exceeds the sum of the baseline (the normal “background”) and the offset (also referred to as “threshold”). Mathematically this is when:

$$\text{Signal (counts)} > \text{Baseline (counts)} + \text{Offset}$$

For example, if the Baseline measurement is 35 counts and the offset is 30 counts, detection occurs for any signal greater than  $35 + 30 = 65$  counts. See Appendix B for a detailed discussion of the detection methodology.

### Mode

The selected mode specifies the type of output(s) that Slick Sleuth can provide and whether the OSM operates autonomously (i.e. the OSM makes detections on a periodic schedule) or idles in standby. The following table lists the modes and for reference the associated “healthy” status word.

<b>Mode</b>	<b>Description</b>	<b>“Healthy” Status Word</b>
<b>0</b>	<b>Standby</b>	<b>0000</b>
<b>1</b>	<b>Autonomous, relay</b>	<b>2000</b>
<b>4</b>	<b>Autonomous, current loop discreet output, and relay</b>	<b>8000</b>
<b>5</b>	<b>Autonomous, current loop scaled output, and relay</b>	<b>A000</b>
<b>6</b>	<b>Autonomous, current loop scaled/corrected output, and relay</b>	<b>C000</b>

### Adaptive Baseline

Automatic correction for ambient conditions. The averaging period in minutes used to compute the correction. Send command ‘M’ with the desired time period in minutes. To disable the adaptive baseline send command ‘M’ with ‘00’ as the minutes. To enable enter 01-99 as the minutes.

Adaptive baseline is used when the distance between the Oil Spill Monitor and the surface is expected to change over time. An example is storm water discharges that intermittently increase the water level, as well as storm water sumps.

### Probability of Detection

This feature is used to define what (how many positive detection samples) constitute an alarm in order to reduce the probability of false detection and/or provide alarm filtering parameters. Two commands work together to establish a filter that rejects spurious detections due to the potential variability of the monitoring environment. The first command establishes a time window over which the OSM evaluates detections. The time window is specified in multiples of four samples, from four to ninety-six samples. The second command sets the minimum percentage of samples within the time window required to declare a detection. The percentage can range from 0 to 100 %. Setting the percentage to 0 % disables the feature, allowing the OSM to declare a detection on any single sample.

As an illustration, an OSM running at a period of 5 seconds takes 12 samples in one minute. If the user wants to use one minute as the sampling window, 12 is entered as the time window. Entering 25 for the minimum percentage of samples, a 25% probability detection percentage is established. With this setup the OSM must make at least 3 detections (25% of 12) within one minute before it will report a detection. Selecting 50% would require 6 detections within the one-minute window and selecting 100% would require 12 continuous detections before a detection would be reported by the OSM.

For more information regarding Probability of Detection refer also to step #5 of the 'Advanced Setup' section in the "Quick Start Instructions" within this manual.

### **3.3 TYPE CONVERSION**

The OSM can be configured in one of two configurations identified as 'TYPE's. The selection of the Type is based on an analysis of the type of pollutant(s) that the OSM is expected to detect. The OSM is factory-configured by default as a Type 2A device, which is most sensitive to heavier hydrocarbon pollutants. If detection of light hydrocarbon pollutants such as jet fuel is required the OSM can be converted to a Type 3 configuration.

The conversion from the default Type 2A configuration to a type 3 configuration is done using the procedure in Section 5 titled 'Conversion Instructions, Type 2A to Type 3, Slick Sleuth SS100'. The optical components for the conversion are provided in a kit (P/N 473586627501). The kit is purchased separate from the SS100.

An OSM that has been configured as a Type 3 can be re-configured to a Type 2A following the procedure in reverse order.

---

**4 MAINTENANCE****4.1 PREVENTATIVE MAINTENANCE**

IOS recommends that the user institute a preventative maintenance (PM) schedule. Detailed PM guidelines are provided in Appendix E.

**4.1.1 Desiccant Packs**

If installed, the desiccant packs should be periodically replaced. The frequency of replacement is highly dependent on the installation and the frequency with which the OSM is serviced. 6 – 12 months is a recommended minimum replacement schedule, but replacement could be required more often in humid environments.

**4.2 LAMP REPLACEMENT**

The flash lamp has very long estimated life, on the order of 5 - 6 years under typical operating conditions. In the event that the lamp fails or degradation becomes evident, as evidenced by a status report message (using the Slick Sleuth Utility Program), perform the Lamp Replacement Procedure in Appendix F.

**4.3 TROUBLESHOOTING**

The built-in test and status reporting functions of the Oil Spill Monitor can identify many problems. In order to access the built-in test and status reporting the Oil Spill Monitor must be locally accessed using the Slick Sleuth Utility Program. See Appendix C for interface definition.

The status report is obtained by sending the 'S' command. The Oil Spill Monitor responds with the following report:

```
AA | s XXXX | y | @(carriage return)(linefeed)
```

XXXX is the status message. Interpretation of the status message is provided below in Section 4.3.1. There are only three problems that can be troubleshot in the field: 1) flash lamp degradation or failure, 2) input power below minimum, or 3) dirt obscuring the optics. The first two problems may be identified through the status report, and the latter by visual inspection. Correction of the first and last problems are dealt with in Sections 4.1 and 4.2. Troubleshooting of the input power is the responsibility of the user.

## 4.3.1 Status Message

The status word can be interpreted as shown in the table below.

Status word	Label	Function
X004	+ 12V low	Regulated + 12V supply below min
X008	- 12V low	Regulated – 12V supply below min
X020	Flash signal low	Flash light output below min
X100	Overtemp	Internal temperature is above specified max
X200	Undertemp	Internal temperature is below specified min
X400	Background high	High ambient light detected, may cause detector sensitivity loss

“X” (the first digit) denotes the current operating mode of the system. Operating mode can be 0, 1, 8, A, or C. See ‘Mode’ in Section 3.3. The remaining three digits provide fault reporting.

As an example, C020 indicates that the unit is operating in mode 6 with a low flash signal status. In this case the current loop will signal the fault with a 3-ma output current.

If any of the fault reporting digits is something other than that shown in the table, the unit has multiple faults. It is recommended that IOS be contacted for assistance in interpreting the message. Otherwise, refer to the last section of Appendix D for the guidelines on interpreting complex status words.

## 4.4 RECOMMENDED SPARES

Qty	Part Number	Description
1	949034404	Xenon Flash Lamp
2	941860003	Desiccant Pack
2	949190180	Ty-wrap

---

**5 DRAWINGS**

<u>Drawing No.</u>	<u>Title</u>	<u>Rev</u>
73586 0084	Installation Drawing	B
73586 1164	Slick Sleuth SS100 Quick Start Instructions	A
73586 1342	Hazardous Location Installation, Slick Sleuth SS100	B
73586 1267	Conversion Instructions, Type 2A to Type 3, Slick Sleuth SS100	A

BC H9G  
 % Hk9J 9K B; 5B; @'69B95Hk'k'989H97 HC F A I GH697 @5F'C :  
 C 6GF1 7 HC B K #k B'k'97 C B9-B8-7 5H98" A I GH69-BG5 @98 K #k'k'9"  
 K B8CK : 57 B; '8CK B"

& DC K 9F 7 56 @9BHF MFI #('B : BDHL  
 5" HkF997 C B81 7 HC Fz% '5K ; 'A B "z%\$ '5K ; 'A 5L"

' BHF: 57 9 7 56 @9BHF MFI #('B : BDHL  
 7 I FF9BH @ C D  
 5" HkF997 C B81 7 HC F G < 9 @98 z & & '5K ; 'A B"  
 F9 @ 5 MG  
 5" & 7 C B81 7 HC Fz & & '5K ; 'A B"

" (" DC K 9F F9E I F9A 9BHG  
 5" GB; @'D < 5G9 57 " , ) ! & \* ( J 57 z ) \$ # \* \$ < n  
 6" C DHC B & \$ ! & , J 87  
 7 " 5 " % 5 G @ ' 6 @ : I G9 A I GH69-BG5 @98 B'k'9 57 BDI H' DC K 9F @B9"  
 8 " 5 & " \$ 5 G @ ' 6 @ : I G9 A I GH69-BG5 @98 B'k'9 87 BDI HDC K 9F @B9"

) " G B5 @ BHF: 57 9"  
 F9 @ 5 MG  
 5" GDGz 89H97 HC B 'GH5 H G"  
 6" GDGz 9E I DA 9BHG5 H G"  
 7 I FF9BH @ C D  
 5" \$ ! & \$ a 5 z G9 @ ! DC K 9F 98  
 6" ( ! & \$ a 5 G B5 @ F9DF 9G9BHG 89H97 H98 G B5 @ @J 9 @  
 " G7 5 @98 \$ ! : I @ BGF I A 9BHF 5B ; 9  
 7 " : 5 I @HG B5 @ " \$ a 5  
 C DHC B5 @ G9F 5 @  
 5" FG ( , )

\* @ 75 @ G9F 5 @ 7 C A A I B 7 5 HC BG f I G6L BHF: 57 9"

+ G99 H97 < B 7 5 @ A 5 B I 5 @ : C F K # B ; 'BGF I 7 HC BG'

" " BGF5 @ 5 HC B A I GH7 C A D @ MK #k 5 @ @ 75 @ 7 C 89G 5 B8'  
 F9 ; I @ 5 HC BG'

" " < 5 N5 F8 C I G @ 75 HC B 'BG5 @ 5 HC B GD97 = 7 B : C F A 5 HC B .

5 " 5 DD @ 7 56 @ 7 9 FH = 7 5 HC BG  
 ! & \$ ' 5 GGM  
 97 9 I ' 9 L J ' & & " \$ \$ ( & L  
 9 I J Y f j U g & & 5 H9L % ) - L

7 @ G9 I D'D @ ; G  
 ? 9 A 5 \$ \* 5 H9L \$ \$ & ( " 89 A ? C % ( ' 5 H9L % & ) + \* ' ( L ' F9 J " \$ " " GF 5 % 5 H9L % % \* I ' GG I 9 . %  
 97 9 I ' 9 A ' \$ + " \$ \$ % & " 97 9 I ' @ % ( " \$ \$ \* , ' GG I 9 B C " \$ " 97 9 I ' GF % " \$ \$ + I ' GG I 9 . %

6" DC K 9F ; F C I B 8 H9FA B 5 HC B .  
 K F 9 ; 5 I ; 9 . % \$ ! % ' 5 K ;  
 7 5 D 57 # M ' + ) ' 5 A B A I A  
 H9FA B 5 HC B ' 6 5 H9G % B ' k 9 I DD9F ' DC F HC B ' C : ' k 9 ; B 8 H9FA B 5 @

7 " 7 56 @ 9 BHF MDC FHG  
 Hk 9 7 56 @ 9 BHF MDC FHG 5 F 9 8 9 G 7 F 6 9 8 B ' BC H9G & 5 B 8 " " C B @ M 7 56 @ ; @ 5 B 8 G'  
 7 9 FH = 98 : C F DFC H97 HC B ' HMD9 " X V " 5 B 8 DFC J # B ; ' 5 A B A I A ' 89 ; F99 C :  
 DFC H97 HC B ' C : @ \* \* B ' 5 7 7 C F 8 5 B 7 9 K # k ' k 9 F 9 E I F 9 A 9 B HG C : ' 97 \* \$ ) & - A 5 M 69  
 I G98 "

8 " I B I I G98 7 56 @ 9 BHF MDC FHG  
 = C B @ MC B 9 C : ' k 9 ' k C ' DC FHG : G I G98 z Hk 9 I B I I G98 ' DC F H A I GH69 D @ ; ; 98 ' K # k '  
 Hk 9 D @ ; ' DFC J # 98 B ' k 9 B G 5 @ 5 HC B ? # I ' BGF I 7 HC B : C F ' B G 5 @ B ; ' k 9 D @ ;  
 5 F 9 DFC J # 98 B ' k 9 ? # I

9" 6 @ 5 B ? 98 ' 9 BHF MDC FH  
 Hk 6 DC F H A I GH69 ; H98 ' K # k ' 5 ' 7 9 FH = 98 ' 7 @ G9 I D'D @ ; ' F 5 H98 ' 9 E I J 5 @ BHC F '  
 ; F 9 5 H9F ' HC ' k 9 A 5 F ? B ; ' C : ' k 9 5 G9 A 6 @ M ' k 9 D @ ; ' G / ' BDHG 5 B 8 5 F 8 z 5 B 8 '  
 Hk F 9 5 8 ' B G9F HC B A I GH69 5 ' A B A I A ' C : ) ' k F 9 5 8 G ' B G 5 @ < 5 B 8 ' Hk < Hk 9 B '  
 Hk < H9B ' 5 : I Fk 9 F % HC ' & : I @ H F B G A 5 ? B ; ' HHC C @ G97 I F9 f K F 9 B 7 < ' Hk < Hk "

F9J GC BG					
NC B9	F9J "	8 9 G 7 F DHC B	97 C	85 H9	5 DDFC J 98
B #5	5	B #5 @ F9 @ 95 G9	B #5	\$ , # % # & \$ & &	GJ 6
B7	6	I D8 5 H9 5 H9L ' 7 9 F H B I A 69 F	+ ' & \$	9/12/2022	S/B

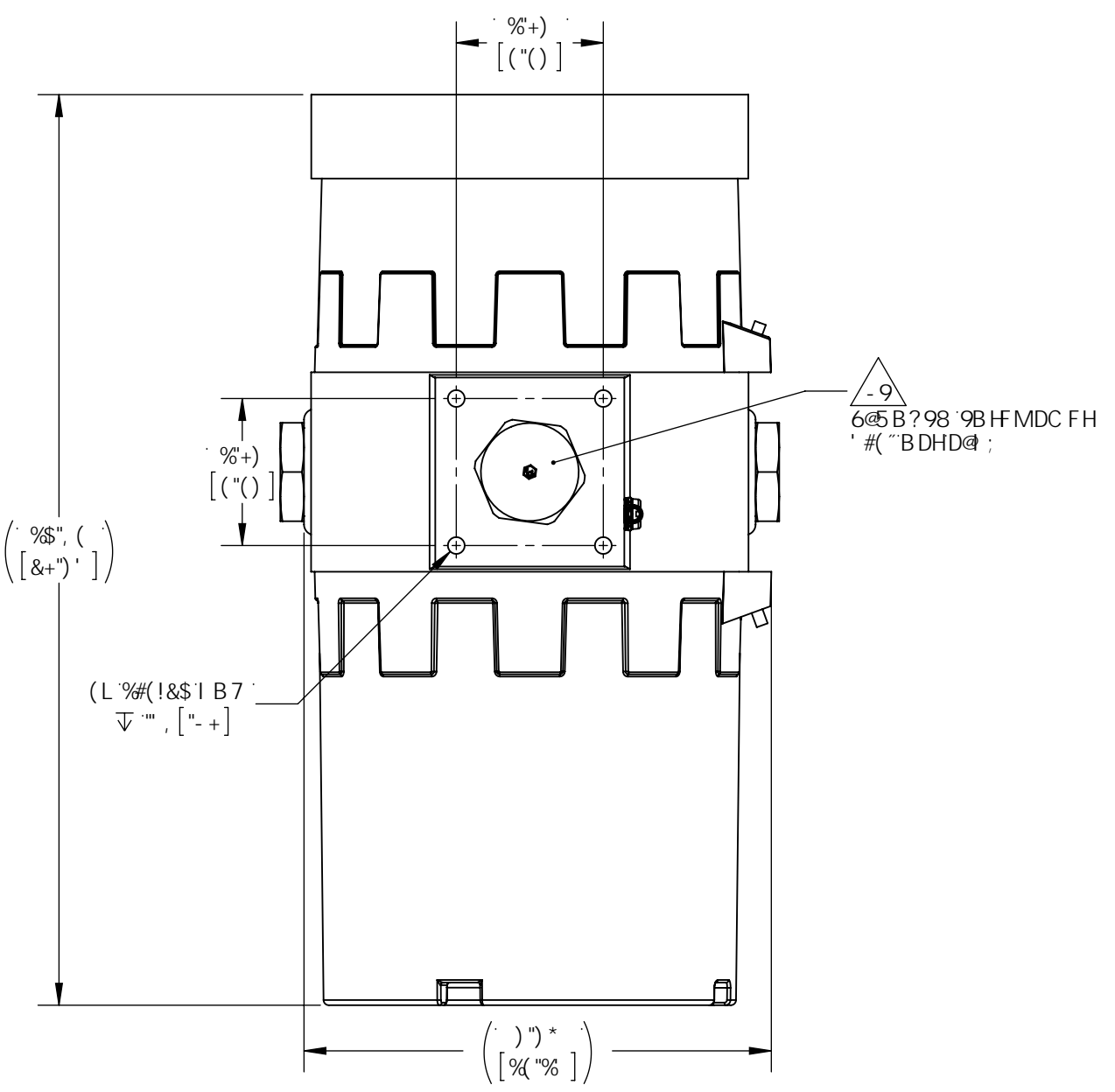
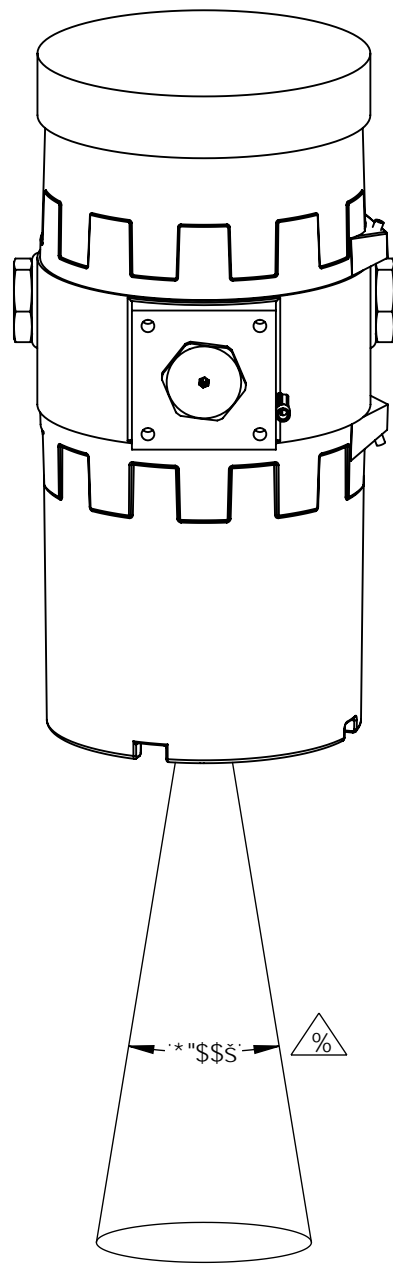

7 C A A 9 B HG	8 A 9 B G C B G 5 F 9 B B a o HC @ F 5 B 7 9 G : F 5 7 H C B 5 @ ± % # & 5 B : I @ 5 F Z A 5 7 < . ± % * 5 B : I @ 5 F z 6 9 B B . ± % * L L L L ± \$ \$ % L L L L ± \$ \$ % L L L L ± \$ \$ %	B 5 A 9	8 5 H9	Kvgt Qe gcp Kvgt Qe gcp U l u n g o u . N N E : 4 2 3 ' k c c e U t g g v U w k g ' E U c p g g . E C ; 4 2 9 3	
DFC DF 9 5 F M 5 B 8 7 C B : 8 9 B H 5 @ Hk 9 B : C F A 5 H C B 7 C B H 5 B 9 8 B Hk 6 8 F 5 K B : ' G H : 9 C C @ 9 D F C D 9 F H M C : ' B H F C 7 9 5 B G M H A G @ 7 " 5 B M F 9 D F C 8 I 7 H C B ' B D 5 F H C F 5 G 5 K < C @ 9 K # k : C I H H : 9 K F H B B D 9 F A G 3 C B C : ' B H F C 7 9 5 B G M H A G @ 7 " 5 D F C < 6 + 9 8 "	8 F 5 K B	A F ?	\$ + # & , # & \$ & &	H H 9 B G 5 @ 5 H C B ' 8 F 5 K B ; A C 8 9 @ G G \$ \$ ' 9 L X 97 9 I ' 9 L J ' & & " \$ \$ ( & L 9 I J Y f j U g & & 5 H9L % ) - L	
7 C 8 9 - 8 9 B H B C " + H N %	B H F D F 9 H C @ F 5 B 7 B ; D 9 F : 5 G A 9 M ( ) ! % - ( ) A 5 H F 5 @ B # 5 : B G B # 5 9 G H K 9 = < H B # 5	DFC > 9 B : F	GJ 6	\$ , # % # & \$ & &	G A 9 8 K ; " " B C "
	DFC 8 A : F	B # 5	B # 5	F 9 J	
		7 I G C A 9 F	B # 5	B # 5	6 + ' ) , * \$ \$ , ( 6
		E 5 # E A G	7 K	\$ , # % # & \$ & &	
		8 C 7 7 H @	A F ?	\$ + # & , # & \$ & &	8 C ' B C H G 7 5 @ G < 99 H % C : ' &
		9 B : F A : F	7 K	\$ , # % # & \$ & &	

E . P X U Z H P [ P + ) , \* P + ) , \* \$ \$ , ( " G X X f k ..... - # / & # & \$ & % % ) , . % ( ' 5 A

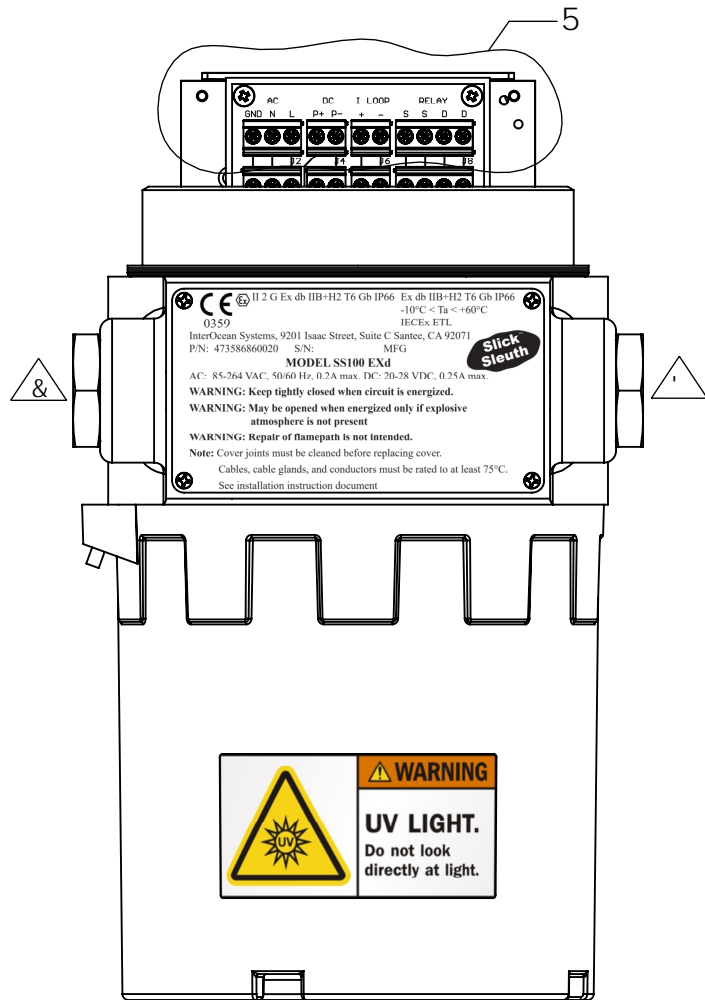
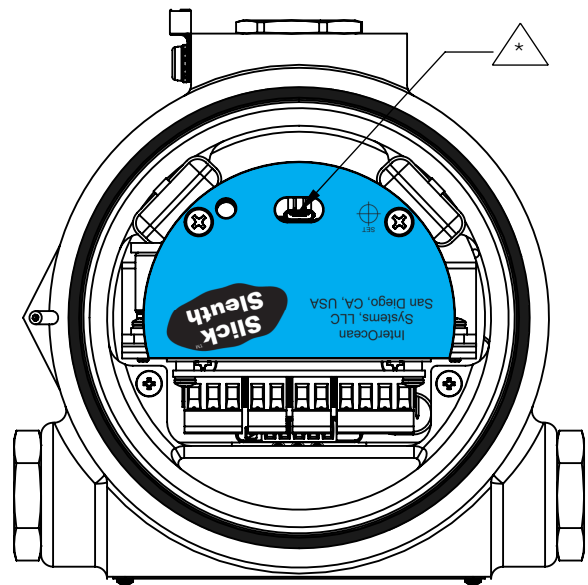

: 9@8 'K F B;  
 f7 C J 9F 'F9A C J 98L

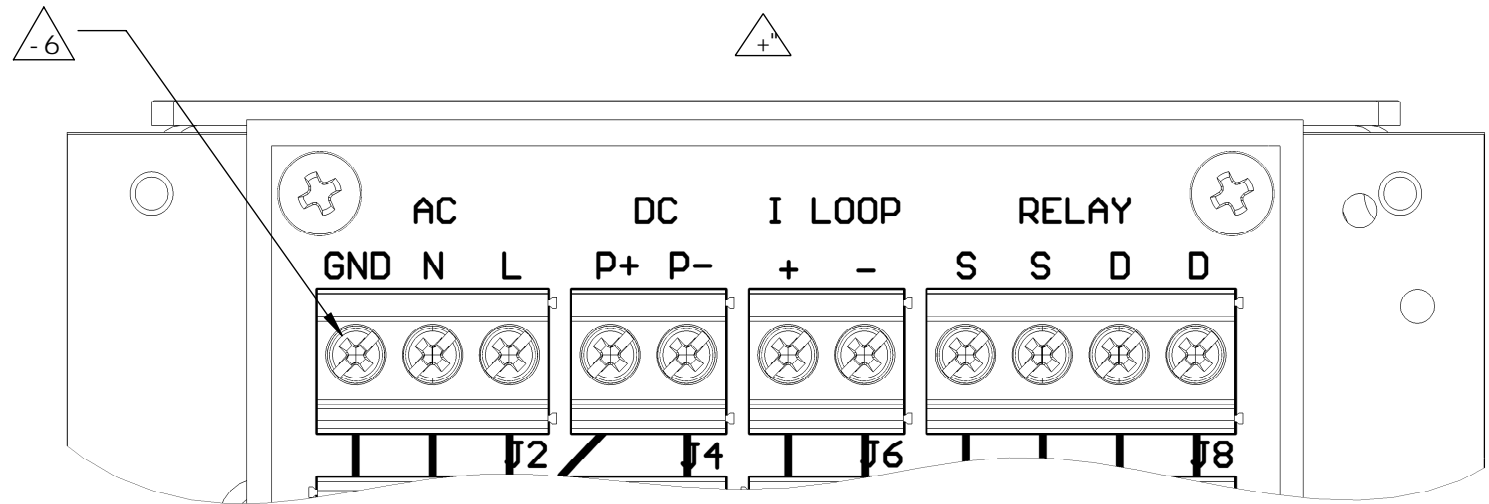

89H5 @5  
 G7 5 @' & . %

8 A 9BGC BG5F9'B jQa a Q HC @F5B7 9G : F57 HC B5@ ± % # & 5B: I @FZA 57 < ± % ° 5B: I @FZ69B 8. ± & ° "L" ± \$' \$& "LL" ± \$' \$& "LLL" ± \$' \$&		<b>Kpvt Qegcp</b> Kpvt Qegcp U[ ugo u. NNE : 423 Kcce U'ggv' U'wkg' E Ucpvgg. EC: 4293	
<b>DFC DF-95FM5B87CB: 89H5@</b> H: 9 B: CFA 5HC B 7 C B15 B 98 -B H: G8F5K -B: GH: 9GC @DFC D9FHM C: BHFC 7 95B GvHFA G @ " 5BM F9DFC 81 7 HC B -B D5FHC F 5G5 K < C @K H: C1 H: K 9K F H8B D9FA GGC B C: BHFC 7 95B GvHFA G @ " GDFC < 6+H8"		H# @. BGF5 @5 HC B '8F5K -B; A C 8 9@GG%\$\$'9LX 97 9l '9LJ '&&'\$\$(&L 9l J Y fJHug &&5 H9L %) -L	
GAN <b>6</b>	8K ; "'BC" + ' ) , * '\$\$, (	F9J <b>6</b>	
8C 'BC HG7 5 @		G< 99H&C : '&	

E . P X U J 7 j b [ P + ' ) , \* P + ' ) , \* '\$\$, ( ' g X X f k ..... - # / & # & \$ & \$ & % ) , . % ( ' 5 A



This document is the Slick Sleuth OSM quick start guide. Several steps refer to information in the Slick Sleuth OSM Technical Manual (TM) so it is advisable to have the Technical Manual on hand.

## INSTALLATION

STEP	INSTRUCTION	TECHNICAL MANUAL REFERENCE						
1	<p>Mount the OSM at the desired location. The enclosure is mounted to a vertical surface using the four holes in the housing boss. Mounting dimensions and clearance requirements are provided in the TM.</p> <p>Install the OSM above the high water line. The optimum height above the water surface is highly dependent on the expected range of the surface elevation. Contact InterOcean Systems (IOS) for a recommendation. Call 858-565-8400 (US) or email sales@interoceansystems.com.</p>	Installation drawing Section 5						
2	<p>Remove the top cover of the OEM. Connect the appropriate power to the OSM. The power cable is brought into the enclosure through a conduit port on the side of the enclosure. The location of the conduit port and the requirements for the cable are provided in the TM.</p> <p>The power cable is terminated at TS1, the terminal block in the upper end of the enclosure.</p> <p><b>DO NOT APPLY POWER AT THIS TIME.</b></p>	<p>Installation drawing Section 5</p> <p>Section 2.3</p> <table border="0"> <tr> <td><u>Type</u></td> <td><u>Figure</u></td> </tr> <tr> <td>AC</td> <td>2</td> </tr> <tr> <td>DC</td> <td>3</td> </tr> </table>	<u>Type</u>	<u>Figure</u>	AC	2	DC	3
<u>Type</u>	<u>Figure</u>							
AC	2							
DC	3							
3	<p>Connect the signal interface to the OSM. The signal cable is brought into the enclosure through a conduit port on the side of the enclosure. The location of the conduit port and the requirements for the cable are provided in the TM. The signal cable is terminated at TS1, the terminal block in the upper end of the enclosure. The termination is a 2-conductor source current loop, and/or an SPST detect relay.</p>	<p>Installation drawing Section 5</p> <p>Section 2.3, Figure 4</p>						
4	<p>Apply power to the OSM. Observe that the indicator light in the cover lights green, indicating that the OSM has a healthy status.</p>							
5	<p>Re-install the top cover on the OSM. Tighten to the point where the top cover seats against the body of the housing. Do not over-tighten. Tighten the top cover set screw to lock the cover in place.</p>							



**QUICK SETUP**

STEP	INSTRUCTION	TECHNICAL MANUAL REFERENCE
1	Place the IOS provided magnetic activation tool over the 'SET' bulls eye under the top glass cover. See Figure below.	Section 2.4.1
2	Observe that the indicator light turns yellow and flashes on – off.	
3	Remove the magnetic activation tool from the top glass cover.	
4	Observe that the indicator light turns green within a few seconds after the removal of the magnetic activation tool.	
5	If the indicator light remains yellow for 10 seconds after the removal of the magnetic activation tool, the OSM is signaling that the "baseline" set exceeds 50% of full scale. The condition may limit the performance of the OSM. Contact IOS Engineering for guidance on Advanced Setup procedures to optimize performance.	

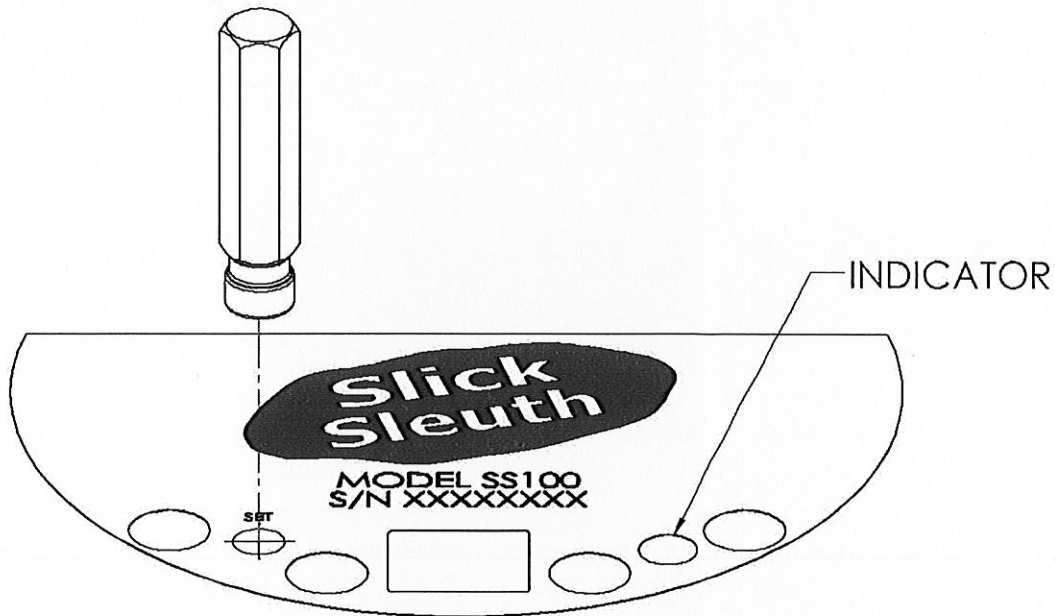



## ADVANCED SETUP

The instructions that follow are provided for the advance user that wishes to change operating parameters beyond the factory setup and the minimum initialization provided in the Quick Setup.

STEP	INSTRUCTION	TECHNICAL MANUAL REFERENCE
1	Connect a PC running Windows XP SP2 or later, Vista, Windows 7 or Windows 8 to the serial port in the upper end of the enclosure. If this is the first time connecting to a OSM using the IOS supplied interface hardware, you may be prompted to install the USB serial driver. Follow the Windows' prompts to do so.	Appendix C.
2	<p>Establish serial communications with the OSM.</p> <p>Serial communications with the OSM is accomplished using the utility program provided by IOS, the Slick Sleuth Utility Program. The following procedures have been developed based on the Utility Program.</p> <p>Install the Utility Program on the PC by inserting the CD. The installation should start automatically. If it does not, go to the root directory on the CD and launch the installation program, setup.exe. Follow the on-screen installation instructions to complete the installation.</p> <p>Launch the Utility Program.</p> <p>Select the BAUD rate for communication with the OSM. Unless specified otherwise, the default BAUD rate for the OSM is 9600 baud.</p> <p>Select the COM port to be used. If in doubt as to the correct COM port, use this procedure:</p> <ul style="list-style-type: none"><li>a. To establish communication between laptop/computer and Slick Sleuth using the Utility Software, it is necessary to select the correct Com Port.</li><li>b. Due to differences in Operating Systems (OS), the following steps may vary on different computer OS'.</li><li>c. Always connect to the USB Port before powering on the laptop computer.</li><li>d. To Begin: Right Click on My Computer and Select Properties OR Select Start menu and Select Control Panel.</li><li>e. Select System.</li><li>f. Select Hardware.</li><li>g. Select Device Manager.</li><li>h. Open Ports (COM &amp; LPT).</li></ul>	Appendix A.



- i. Make a note of all Com Port assignments, including which one is connected to the Slick Sleuth/USB interface.
- j. If you cannot determine which Com Port is assigned to the Slick Sleuth/USB interface, try disconnecting the Slick Sleuth/USB cable and note which Com Port is no longer assigned. This should indicate the Com Port assigned to your Slick Sleuth/USB interface.
- k. This Com Port number must be input using the Utility Software in order to establish real-time two-way communications with a laptop computer.

NOTE

The operating system will assign a new/unique Com Port number to each SS100, unless the Com Port assignment is manually changed through the Device Manager

Enter the address (two digits) for the OSM in the Address box, if the OSM has an address other than '00'. The default address is '00' so this step may not be required.

Select the 'L' Set Mode command, click 'OK' when asked to enter the mode (do not enter a mode value), then click on the SEND COMMAND button. If the OSM is powered up and connected correctly, the OSM should reply with an answer in the Message Received box. The answer should look similar to this: **00 L O k @**. The number following the 'L' defines the operating mode of the OSM.

If the OSM responds, continue with initialization. If the OSM responds with the message "Timeout>>", it will be necessary to determine the reason for the non-response. Verify that the OSM has power, verify the wiring between the PC and the OSM, and verify that the selected COM port is functional and/or choose another COM port until you have selected one that responds.

3 Initialize the OSM and Establish Baseline

If the 'L' command in step 2 returned a number other than 0, it is necessary to change the mode to facilitate the initialization. If this is the case, follow these steps:

1. Record the mode number read in Step 2 (you will need to re-enter it into the OSM at a later step).
2. Select the 'L' command and enter 0 when asked to enter the mode.
3. Select 'OK'.
4. Click on the SEND COMMAND button.
5. Observe that the OSM responds with **00 L O k @** or a similar response.

Verify that the conditions below the OSM are typical (i.e. that there is no oil present or other abnormal conditions). Select the 'I' command, then click on the SEND COMMAND button. This command tells the OSM to make a baseline measurement. Record the response from the OSM for future reference.



4	<p>Read and/or Change the Offset</p> <p>The Offset is used to set the Detection Threshold as follows: Detection Threshold = Baseline + Offset</p> <p>Read the existing Offset by following these steps:</p> <ol style="list-style-type: none"><li>1. Select the 'T' command, then select 'OK' without entering a data value.</li><li>2. Click on the SEND COMMAND button.</li><li>3. Observe that the OSM responds with <b>00 T XXXXX x @</b> where <b>XXXXX</b> is the existing Offset.</li></ol> <p>To change the Offset to a new Offset (lower for greater sensitivity, higher for lower sensitivity), follow these steps:</p> <ol style="list-style-type: none"><li>1. Select the 'T' command and enter the new Offset value (4 digits, including zeroes if necessary).</li><li>2. Select 'OK'.</li><li>3. Click on the SEND COMMAND button.</li><li>4. Observe that the OSM responds with <b>00 T XXXXX x @</b> where <b>XXXXX</b> is the new Offset.</li></ol> <p>If the 'L' command had to be used to change the mode in Step 3, restore the operational setup by following these steps:</p> <ol style="list-style-type: none"><li>1. Select the 'L' command and enter the previously recorded operational setting when asked to enter the mode.</li><li>2. Select 'OK'.</li><li>3. Click on the SEND COMMAND button.</li><li>4. Observe that the OSM responds with <b>00 L X a @</b> where <b>X</b> is the operational setting you entered. The character (the checksum) following the X may be different from written here.</li></ol>	Section 2.4 Section 3.2, Appendix B
---	--	---



5	<p><b>Probability of Detection</b></p> <p>The 'd' and 'e' commands are used to lower the probability of falsely detecting an oil slick. These commands work in conjunction with each other to establish a filter that will reject spurious detections due to the variability of the natural environment. The 'e' command is used to set a sample window from 4 to 96 in increments of 4 over which the number of detected events is evaluated. When the number of detected events exceed a percentage of the window size, as set by the 'd' command, the OSM will indicate that a slick has been detected.</p> <p>In order to execute the 'd' and 'e' commands the OSM must be in the idle state. This is done by issuing the 'L' command as follows:</p> <ol style="list-style-type: none"> <li>1. Select the 'L' command and enter 0 when asked to enter the mode.</li> <li>2. Select 'OK'.</li> <li>3. Click on the SEND COMMAND button.</li> <li>4. Observe that the OSM responds with <b>00 L 0 k @</b> or a similar response.</li> </ol> <p>The 'd' command is used to set one of five percentage values from 000, 025, 050, 075 and 100 percent. This function is disabled when the percentage is set to 000. To change the percent window size to a new value follow these steps:</p> <ol style="list-style-type: none"> <li>1. Select the 'd' command and enter the new percent value (3 digits, including leading zeroes if necessary).</li> <li>2. Select 'OK'.</li> <li>3. Click on the SEND COMMAND button.</li> <li>4. Observe that the OSM responds with <b>00 d XXX x @</b> where <b>XXX</b> is the new percent.</li> </ol> <p>The 'e' command is used to set the size of the detection window from 4 samples to 96 samples in increments of 4. To change the window size to a new value follow these steps:</p> <ol style="list-style-type: none"> <li>1. Select the 'e' command and enter the new window value (2 digits, including leading zeroes if necessary).</li> <li>2. Select 'OK'.</li> <li>3. Click on the SEND COMMAND button.</li> <li>4. Observe that the OSM responds with <b>00 e XX x @</b> where <b>XX</b> is the new percent.</li> </ol> <p>Use the 'L' command as described above to put the OSM back into operation under control of the new settings.</p>	<p>'d' Command</p> <table border="1"> <thead> <tr> <th>Value</th> <th>Percent</th> </tr> </thead> <tbody> <tr> <td>000</td> <td>Disable</td> </tr> <tr> <td>025</td> <td>25%</td> </tr> <tr> <td>050</td> <td>50%</td> </tr> <tr> <td>075</td> <td>75%</td> </tr> <tr> <td>100</td> <td>100%</td> </tr> </tbody> </table>	Value	Percent	000	Disable	025	25%	050	50%	075	75%	100	100%
Value	Percent													
000	Disable													
025	25%													
050	50%													
075	75%													
100	100%													
6	<p><b>Placing the OSM into operation</b></p> <p>Once the baseline, background values and optional parameters have been set, the OSM can be placed into autonomous operation (if not already done so) using the 'L' command.</p>	<p>Section 3 Appendix A</p>												



## 1 Specific Condition for Use:

- Keep cover tightly closed when circuits are energized.
- May be opened when energized only if explosive atmosphere is not present.
- When mounting the enclosure in a hazardous area, all entries into the enclosure shall be sealed with cable glands, blanking elements and thread adapters certified for protection type 'db' and providing a minimum degree of protection of IP66 in accordance with the requirements of IEC 60529.
- The hazardous location solutions reducers shall not be used for the direct inter-connection of enclosures.
- Only one hazardous location solution reducer shall be used with any single cable entry on the associated equipment.
- All conduit sealing fittings must be certified as flameproof "db" and have a minimum IP66 rating equal to the marking on the enclosure.
- When a conduit fitting device is used with the equipment the end user is required to fit an Ex db certified conduit seal (for example a conduit stopping box) as close as reasonably practical to the entry. The distance from the seal to the enclosure shall not exceed the diameter of the conduit or 50mm, whichever is the lesser.
- The OX3 close up plug is for one time use only.
- The equipment window was tested for low risk of mechanical danger and must be installed in such a way so that the sapphire window is not likely to be impacted.
- Equipment must be mounted with the detector window facing down.



## 2 Specifications

Input Power AC

Input Voltage: 85-264 VAC

Input Frequency: 50/60 Hz

Input Current: 0.2A maximum. (115/230 VAC)  
0.1A typical

Inrush Current: 15A typical (115/230 VAC)  
30A maximum

DC

Input Voltage: +20 to +28 VDC

Input Current: 150 mA average  
1.25 A peak

Operating Temperature Range -10°C to +60°C

Weight 10 lb. (4.5 kg)

Detection Range 0.25m to 1.0m

Communications Interfaces

Oil Detect and Status Relays

Configuration: SPST

Rating: 110 VDC / 0.3A / 33W

30 VDC / 2.0A / 60W

120 VAC / 0.5A / 60VA

240 VAC / 0.25A / 60VA

0-20 mA Current Loop

Source Mode 0 – 650  $\Omega$

Compliance:

Serial Communications

Local access: USB

Option: 4-wire RS-485

Or

2-wire RS-485



### Hazardous Locations Ratings

ATEX

 II 2 G Ex db IIB+H<sub>2</sub> T6 Gb IP66  
-10°C ≤ Ta ≤ +60°C  
ExVeritas 22ATEX1359X  
EN 60079-0, EN 60079-1

IEC

Ex db IIB+H<sub>2</sub> T6 Gb IP66  
-10°C ≤ Ta ≤ +60°C  
IECEX EXV 22.0042X

Standards:

IEC 60079-0:2011, 6<sup>th</sup> Edition  
IEC 60079-1:2014, 7<sup>th</sup> Edition

### 3 Recommended Spares

Qty	Part Number	Description
1	9-4903 4404	Xenon Flash Lamp
1	4-73586 1262-00	Source Control Drawing, 3/4 NPT Plug, EXd











## 4 Installation

### 4.1 Warnings and Cautions

#### **READ ALL INSTRUCTIONS**

Failure to follow the following statements may result in serious personal injury or death.

-  **WARNING:** Risk of explosion. Keep cover tightly closed when circuits are energized.
-  **WARNING:** May be opened when energized only if explosive atmosphere is not present.
-  **WARNING:** To reduce the risk of explosion, conduit must be sealed within 18" of the enclosure or according to the requirements of local codes and regulations.
-  **CAUTION:** Installation must be performed according to the installation and wiring drawings contained in this manual.
-  **WARNING:** Repair of flame path is not intended.
-  **CAUTION:** Installation must be done by appropriately qualified personnel.
-  **CAUTION:** Installation must conform to all local electrical codes and regulations.
-  **CAUTION:** Clean cover joints before re-assembling unit.

### 4.2 Installation Drawing

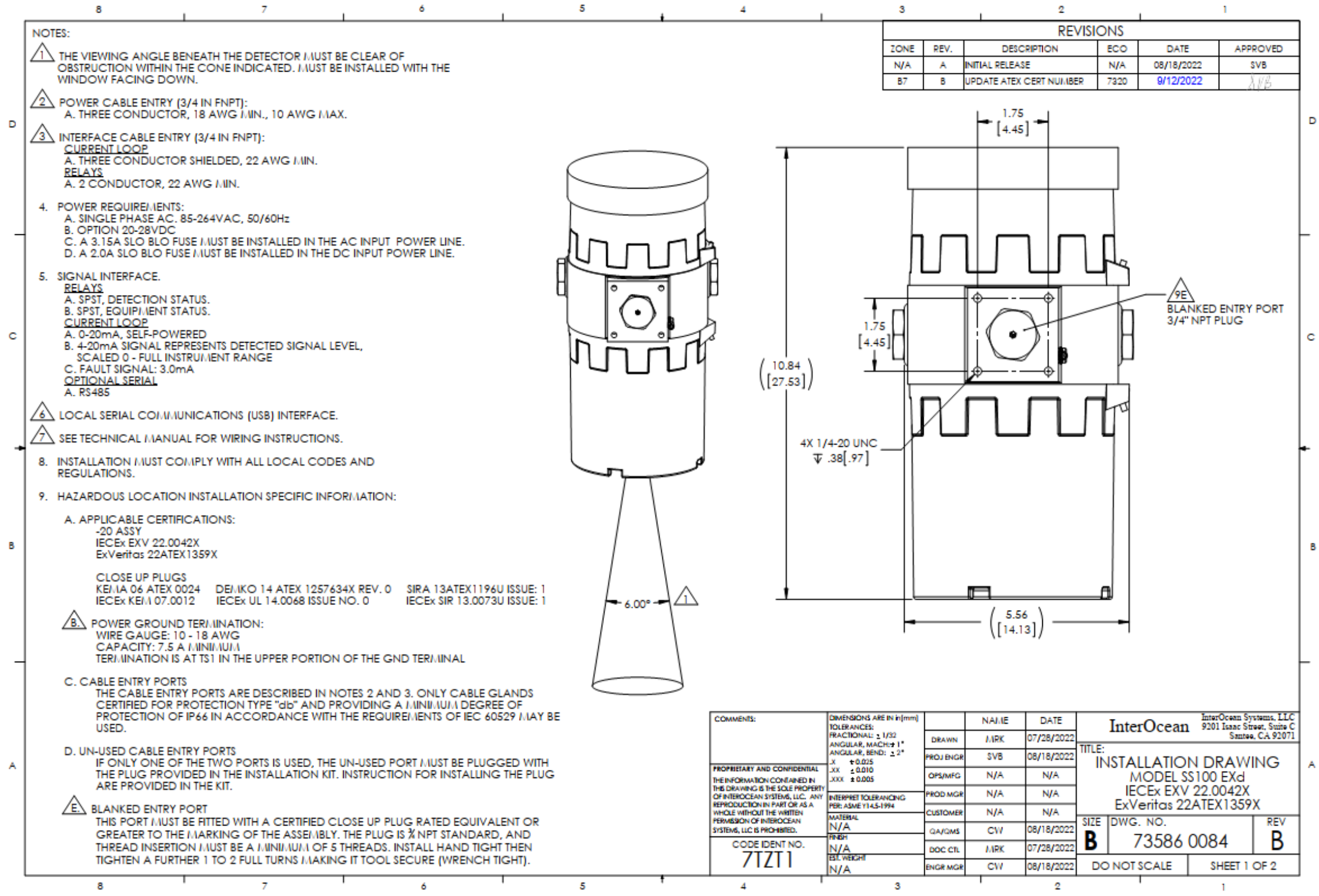

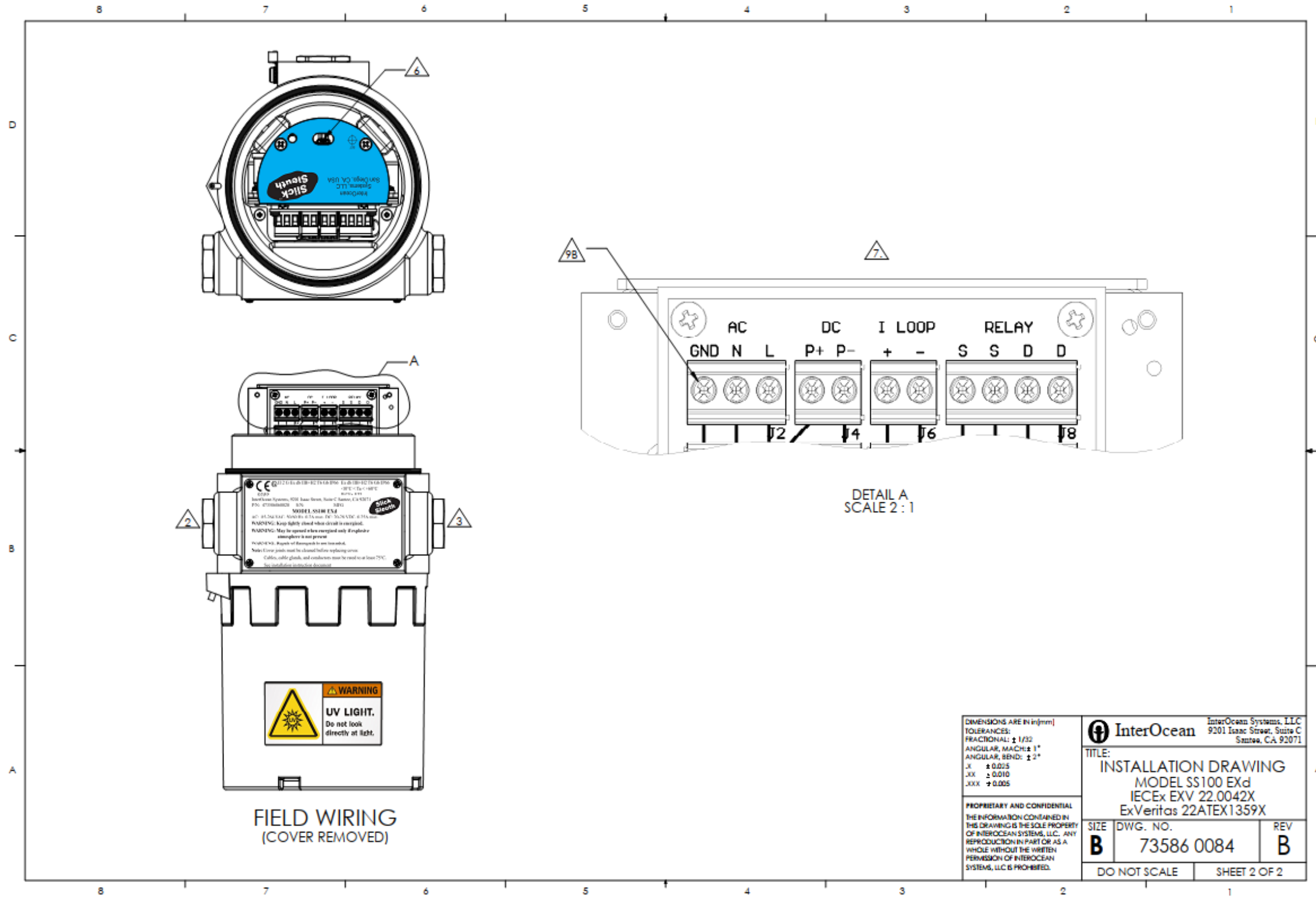

DIMENSIONS ARE IN (mm) TOLERANCES: FRACTIONAL: ± 1/32 ANGULAR, MATCH: ± 1° ANGULAR, BEND: ± 2° .X ± 0.025 .XX ± 0.010 .XXX ± 0.005		InterOcean Systems, LLC 9201 Isaac Street, Suite C Santee, CA 92071	
<b>InterOcean</b> TITLE: <b>INSTALLATION DRAWING</b> MODEL SS100 EXd IECEX EXV 22.0042X ExVeritas 22ATEX1359X			
PROPRIETARY AND CONFIDENTIAL THE INFORMATION CONTAINED IN THIS DRAWING IS THE SOLE PROPERTY OF INTEROCEAN SYSTEMS, LLC. ANY REPRODUCTION IN PART OR AS A WHOLE WITHOUT THE WRITTEN PERMISSION OF INTEROCEAN SYSTEMS, LLC IS PROHIBITED.	SIZE <b>B</b>	DWG. NO. <b>73586 0084</b>	REV <b>B</b>
DO NOT SCALE		SHEET 2 OF 2	

Q:\drafting\73586\73586 0084.sld.drw 9/12/2022 11:58:14 AM



## 5 Preventative Maintenance (PM)

### Slick Sleuth Oil Spill Monitor

**Every 30 Days, 60 Days, or As Required PM.** *See attached check list for example.*

- 1) Conduct a thorough physical inspection of the Oil Spill Monitor.

Check the optics for obstructions; i.e. spider webs, salt, water spots, or foreign film. *If necessary* clean optical glass using the following procedure:

- i. Use compressed dry air and/or distilled water to flush away any film or debris build-up on the surface of the glass window.
  - ii. **Caution:** when examining the glass surface on the underside of the sensor it is recommended that the unit be stopped (mode 0) to avoid extended direct eye exposure to UV light.
  - iii. If dirt or impediment is still present after rinsing with distilled water, use lens tissue or a soft clean cloth to wipe away and clean optical glass surfaces. Commercial glass cleaner may be used if necessary to remove difficult dirt.
  - iv. Use caution not to scratch optical glass.
  - v. Use caution so that no oil or fingerprints are left on the optical glass surface.
  - vi. Return unit to normal operating mode and setup parameters.  
(Section 3.2 of the manual covers this procedure).
- 2) Inspect the sample area (water/ground) directly beneath the sensor for any obstructions, contaminants, and abnormalities. Observe area both above, on and below the water line.
  - 3) Periodic field assurance test may also be conducted. At a fixed distance (for example ½ meter below sensor) place a sample of oil. If using oil is not an option, a sheet of white paper can be used to simulate oil, or material smeared with oil. For consistency the same type(s) and amount(s) of oil or 'oil simulating' material should be used to test alarm. Place oil beneath the sensor and confirm that local alarm activates, as well as in control room or wherever remote oil alarm output is monitored. Likewise confirm that PLC / externally activated devices such as pumps, valves, skimmers activate accordingly.
  - 4) If any settings are changed using the Utility Program, record changes in instrument record and/or on check list. To check existing settings, select any command (i.e. Offset "T" command). Enter no value (leave blank), click OK, and then Send Command. Existing value is reported in message received window.



**Every 6-Month, 1-Year, or As Required PM. See attached check list example.**

- 5) Conduct thorough physical inspection described in item 1 above. Additionally:
- 6) Put the unit into mode 0 and power off prior to interior inspection and cleaning.
- 7) Inspect the conduit fittings to ensure they are secure.
- 8) Inspect each cover seal. Check for cracking, tearing, and for proper seal.
- 9) Inspect enclosure interior for debris (wire strands, loose hardware, etc.) and remove as necessary. If dust build-up is present, carefully vacuum interior and/or blow out enclosure using compressed dry air.
- 10) Clean the enclosure of all debris and particulate matter. Take care not to spray cleaner inside optical tubes.
- 11) Clean the window as described in Step 1.
- 12) Perform diagnostic check:
  1. Connect portable computer to the unit.
  2. Using SS Utility Program, put unit into mode 0 ("L" command).
  3. Issue a Status Request command ("S" command).  
The result of a fully functional unit should be 0000. See Figure 1 for Example.  
(If using SS Utility Program Rev 1.45 or later, all indicators should be green)
  4. If a number other than 0000 is present (if diagnostic fault is detected); consult the Status Report table in Appendix D (Operations Manual).
  5. Troubleshooting is covered in Section 4.3 of the manual.
  6. For further assistance contact InterOcean Systems: tel.858.565.8400 USA.
- 13) Issue a "Debug" (1) command to check the flash count.
  1. This procedure is located in Appendix F.
  2. Flash count numbers will be the last 10 numbers in column 4 of the large window on the main screen. The flash count appears below this column. See Figure 2 for Example.
  3. Calculate a new flash threshold value that is 60% of the flash count number observed in Step b. Enter the new value into the OSM by performing the following steps using the Utility Program:
    1. Go to the Real Time Logging window, select 'Factory Setup', then enter the factory password.
    2. Return to the main window.
    3. CLEAR the Commands list.
    4. Select 'Flash Threshold (Y)'.



5. When the data entry window appears enter the 60% value calculated as the new flash threshold value. Select 'OK'
6. SEND the new value to the Slick Sleuth

EXAMPLE:

The flash count number observed in Step b. is 676. Calculate the new flash threshold value:

$$\text{Flash Threshold Value} = 60\% * 676 = 405$$

This new value would be entered into the Slick Sleuth using the command sequence in Step c. The value would be entered as '0405'.

- 14) The anticipated flash lamp life is approximately 2½ - 3 years at the highest sampling rate. The fault alarm will alert the user to lamp failure. The lamp can be replaced at that time, or can be treated as a periodic / preventative maintenance item and replaced on a cyclical schedule. Note that if lamp failure is suspected, the first course of action is to perform items 12 and 13 above. If lamp replacement is necessary (either failure or as PM), please refer to Section 4.2 for lamp replacement procedure. This will also direct you to Appendix F for completing the replacement process.



**Figure 1** (on right)  
 #1 Status 0000 (in Message Received window). No faults  
 #2 Status Green Light. No fault.

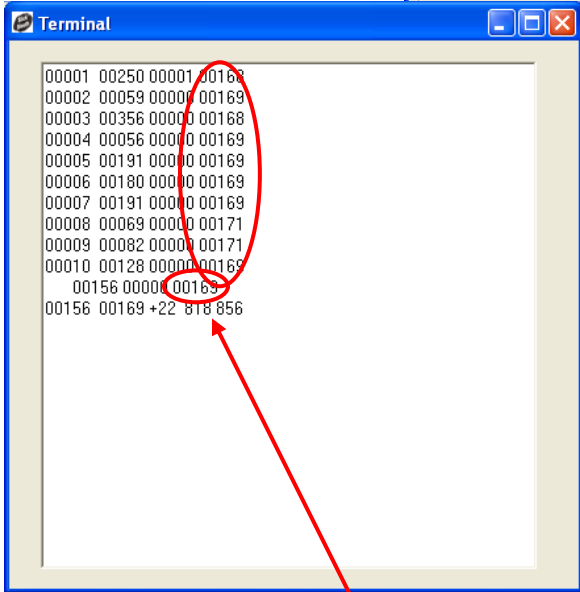
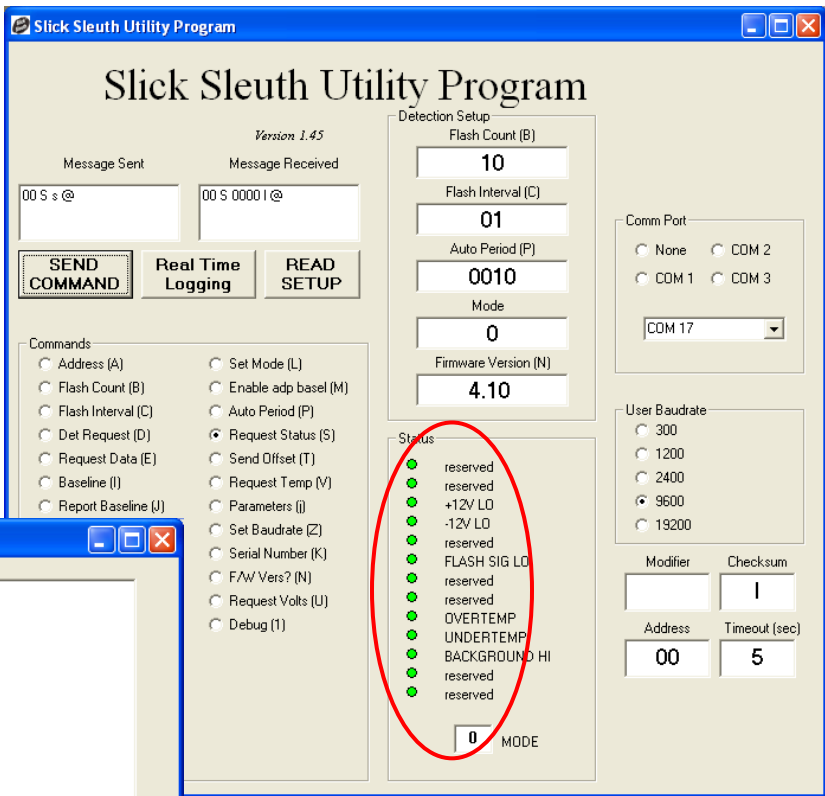

**Figure 2** (on left)  
 #3) Debug command sent & received. All values within  $\pm 10\%$ .  
 Sensor/flash healthy.

Flash Detection Count



Example: PM Checklist & Instrument Record



### PREVENTATIVE MAINTENANCE SS100 CHECK LIST

		Name: <input style="width: 90%;" type="text"/>
		Date: <input style="width: 90%;" type="text"/>
<input checked="" type="checkbox"/>		Comments <input style="width: 90%;" type="text"/>
<b>Preventative Maintenance - Monthly</b>		
1 Physical Inspection	<input type="checkbox"/>	<input style="width: 90%;" type="text"/>
2 Inspect Sample Area	<input type="checkbox"/>	<input style="width: 90%;" type="text"/>
3 Inspect Accessories	<input type="checkbox"/>	<input style="width: 90%;" type="text"/>
4 Field Assurance Test (Optional)	<input type="checkbox"/>	<input style="width: 90%;" type="text"/>
5 Settings - Utility Program (Optional)	<input type="checkbox"/>	<input style="width: 90%;" type="text"/>
<b>Preventative Maintenance - Semiannually or Annually</b>		
6 Physical Inspection / Items 1 - 5	<input type="checkbox"/>	<input style="width: 90%;" type="text"/>
7 Set Mode to "0"	<input type="checkbox"/>	<input style="width: 90%;" type="text"/>
8 Inspect - Cable Glands	<input type="checkbox"/>	<input style="width: 90%;" type="text"/>
9 Inspect - Cover Seals	<input type="checkbox"/>	<input style="width: 90%;" type="text"/>
10 Inspect - Enclosure	<input type="checkbox"/>	<input style="width: 90%;" type="text"/>
11 Clean Window	<input type="checkbox"/>	<input style="width: 90%;" type="text"/>
12 Clean Enclosure & Accessories	<input type="checkbox"/>	<input style="width: 90%;" type="text"/>
13 Diagnostic Check	<input type="checkbox"/>	<input style="width: 90%;" type="text"/>
14 Flash Count Check	<input type="checkbox"/>	<input style="width: 90%;" type="text"/>
15 Flash Lamp Check	<input type="checkbox"/>	<input style="width: 90%;" type="text"/>
16 Return to Normal Operating Mode	<input type="checkbox"/>	<input style="width: 90%;" type="text"/>
<b>Saved Configuration</b>		<b>Record Value</b>
S Request Status	(i.e. 0000)	<input style="width: 90%;" type="text"/>
J Report Baseline	(i.e. 50)	<input style="width: 90%;" type="text"/>
T Send Offset	(i.e. 60)	<input style="width: 90%;" type="text"/>
L Set Mode	(i.e. 4)	<input style="width: 90%;" type="text"/>
P Automatic Mode Period	(i.e. 0005 = 5 sec)	<input style="width: 90%;" type="text"/>
M Enable Adaptive Baseline	( i.e. 00 Disabled / XX Enabled)	<input style="width: 90%;" type="text"/>
B Flash Count	(i.e. 10)	<input style="width: 90%;" type="text"/>
C Flash Interval	(i.e. 01 = 1 m sec)	<input style="width: 90%;" type="text"/>



## 6. Slick Sleuth Lamp Replacement Instructions

### References

Dwg. No. 735861164      Slick Sleuth OSM Quick Start Instructions  
P/N 73586600103      Slick Sleuth Utility Program, V1.46

### Procedure

#### NOTE

The following procedures have been developed based on use of the Utility Program.

- 6.1 Disconnect power to the Oil Spill Monitor.
- 6.2 Remove the cover on the bottom of the enclosure.
- 6.3 Locate the flash optics assembly as shown in Figure 1.
- 6.4 Remove the flash optics assembly by unscrewing it from the mounting plate.
- 6.5 Remove the flash lamp by pulling it downward, away from the trigger socket. Do not twist the flash lamp.
- 6.6 Plug the replacement flash lamp into the trigger socket. Wear cotton gloves or similar handling materials to avoid leaving finger oil or other dirt or residue on the flash lamp.
- 6.7 Re-assembly is completed in reverse order.
- 6.8 After a flash lamp is replaced an initialization measurement must be done (See Section 2.4 Initialization). Flash lamps vary in performance, so it is critical that the Oil Spill Monitor be initialized to achieve good performance.
- 6.9 Cover each optics hole with opaque black electrical tape. Do not let the tape touch the surface of the optics.
- 6.10 Establish serial communications with the OSM using Step 2 in the Advanced Setup section of the Quick Start Instructions.
- 6.11 If the 'L' command returned a number other than 0, it is necessary to change the mode to facilitate this procedure. Write down the number returned in the 'L' command for re-initialization after completion of this procedure, then proceed with the following steps:
  1. Select the 'L' command and enter 0 when asked to enter the mode. Select 'OK'.
  2. Click on the SEND COMMAND button.



3. Observe that the OSM responds with 00 L 0 k @ or a similar response.
- 6.12 Click on the REAL TIME LOGGING button.
- 6.13 In the Real Time Logging window click on the Factory Setup button and enter the password '73586'.
- 6.14 Return to the main window.
- 6.15 Select the 'H' command and enter 0000 when asked to enter the EMI Offset. Click on the SEND COMMAND button.
- 6.16 Select the 'D' command. Click on the SEND COMMAND button. Wait for the unit to stop flashing before sending the next command.
- 6.17 Select the 'E' command. Click on the SEND COMMAND button.
- 6.18 The 5 digit number reported is the measured EMI offset. Record for reference.
- 6.19 Select the 'H' command and enter the number recorded in Step 2.10 when asked to enter the EMI Offset. Click on the SEND COMMAND button.

#### NOTE

The entered number must be 4 digits in length. For example, if the measured and reported EMI Offset was '00023', enter '0023'.

- 6.20 Remove the black electrical tape from the optics holes.
- 6.21 Select the '1' (Debug) command. Click on the SEND COMMAND button.
- 6.22 Wait approximately 30 seconds for the unit to complete its full self-diagnostics test. The response will appear in the large text box.
- 6.23 Locate the number (the flash detection counts) under the fourth column (just above the last row). See Figure 2.
- 6.24 Calculate a number that is 60% of the number read in Step 3.3. Round the number down to a whole integer. Example: the number read in Step 3.3 is 676. Calculating the value,  $60\% * 676 = 405.6$ . Rounding down, the number becomes 405.



- 6.25 Using the utility program, perform the following steps:
  - 6.25.1 Go to the Real Time Logging window and select 'Factory Setup'. Enter the password '73586'.
  - 6.25.2 In the main window select 'Flash Threshold (Y)'.
  - 6.25.3 When the data entry window appears enter the value calculated in Step 3.4, then click on 'OK'. For the example in Step 3.4, the value entered would be '0405'.
  - 6.25.4 SEND the new value to the OSM.
- 6.26 Select the 'L' command and enter the number recorded in Step 2.3 to restore the normal operating mode.
- 6.27 Click on the SEND COMMAND button.
- 6.28 Observe that the OSM responds with 00 L X a @, and that the OSM returns to its normal operating mode. X is the number you entered for the mode. The '00' and the checksum may be different than written here.

PROCEDURE COMPLETE

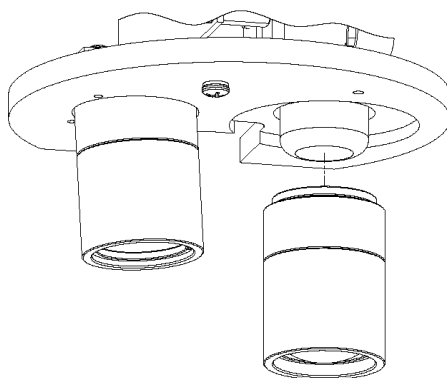
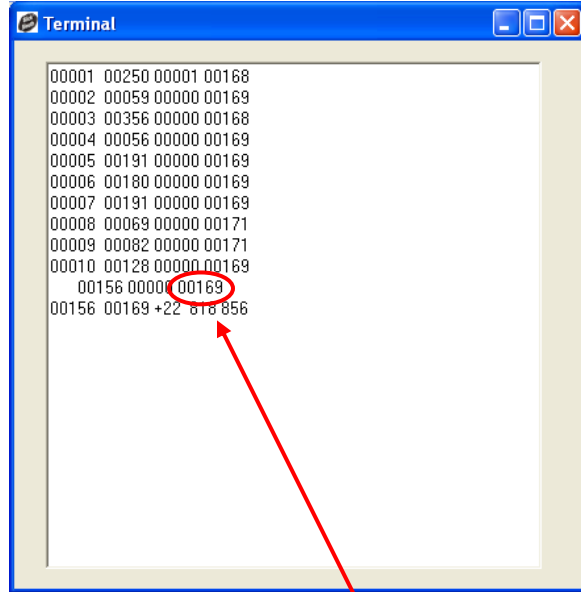

Figure 1  
Flash Lamp



Flash Detection Count

Figure 2

## SCOPE

This procedure provides instructions for field conversion of a Slick Sleuth SS100 from a Type 2A device to a Type 3 device or the reverse, as required by installation requirements. Each device Type provides detection capability for a specific group of fluorescent pollutants, typically hydrocarbons. At installation or during operation it may be beneficial to change the detection Type to optimize performance at the site. This procedure and the kit optics provide that capability.

## GUIDELINES

The SS100 is factory-configured by default as a Type 2A device, which is most sensitive to heavier hydrocarbon pollutants. If detection of light hydrocarbon pollutants such as jet fuel is required the factory-configured SS100 should be reconfigured using this procedure to a Type 3 device.

## REFERENCE

For identification purposes the optics assemblies are marked as follows:

ASSEMBLY DESCRIPTION	PART NO.	MARKING
Flash Optics, Type 2A	4735866239-01	6239-01
Flash Optics, Type 3	4735866239-02	6239-02
Detector Optics, Type 2A	4735866238-01	6238-01
Detector Optics, Type 3	4735866238-02	6238-02

## PROCEDURE

### CAUTION

When handling an optics assembly use care to avoid finger contact or other contaminant contact with the glass components of the optics assembly.

1. Disconnect power to the SS100.
2. Remove the lower cover from the device. See Figure 1.
3. Remove the flash optics assembly. See Figure 2. Use care to avoid finger contact with the flash lamp.
4. Replace the flash optics assembly with the flash optics assembly from the Accessory Kit.
5. Remove the detector optics assembly. See Figure 3.
6. Replace the detector optics assembly with the detector optics assembly from the Accessory Kit.

Use care screwing the detector optics assembly into the base plate. The threaded hole has fine pitch threads tilted at an angle a few degrees off vertical.

7. Locate the two jumpers on the Controller board as shown in Figure 4A.
8. Pull the jumper at JP1 off of the header and re-install in the position shown in Figure 4B.
9. Pull the jumper at JP2 off of the header and re-install in the position shown in Figure 4B.
10. Replace the lower cover on the device.
11. Wrap and store the removed optics assemblies in a dry location to retain for future use if required.
12. Apply power to the SS100.



InterOcean Systems, LLC  
3738 Ruffin Road,  
San Diego, CA 92123

TITLE:

CONVERSION INSTRUCTIONS  
TYPE 2A TO TYPE 3  
SLICK SLEUTH SS100

SIZE

A

DWG NO.

73586 1267

REV

A

DO NOT SCALE

SHEET 1 OF 4

13. Setup the SS100 to match the Type of the installed optics.

- Connect a PC running the Utility Program to the USB port under the top cover of the SS100.
- On the Real Time Logging window enter the factory password (provided under separate cover).
- On the main window select 'Type' and enter the appropriate Type number. SEND to the device.

14. CONVERSION COMPLETE. If the SS100 has been removed from its installation site restore the installation. Complete the installation by performing the Quick Start instructions from the technical manual to initialize the SS100. Restore any configuration parameters that may have been changed during the conversion process, then enter the desired Mode to start the SS100 running.

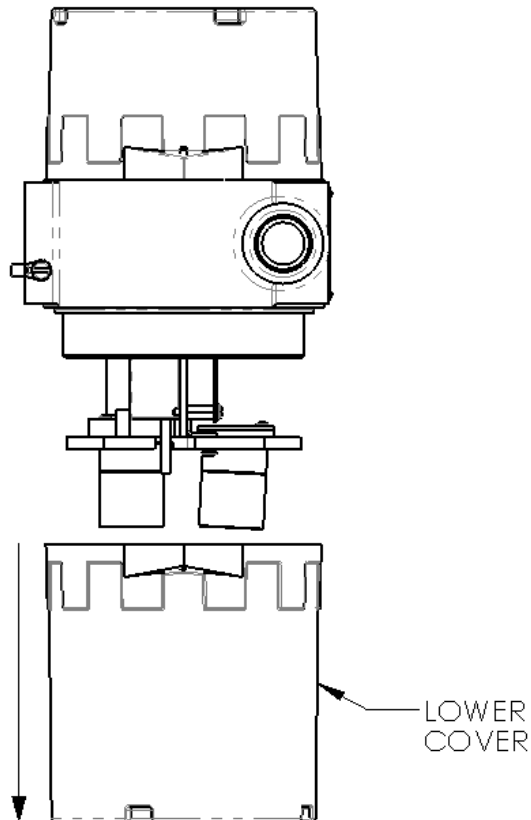

Figure 1

Lower Cover Removal

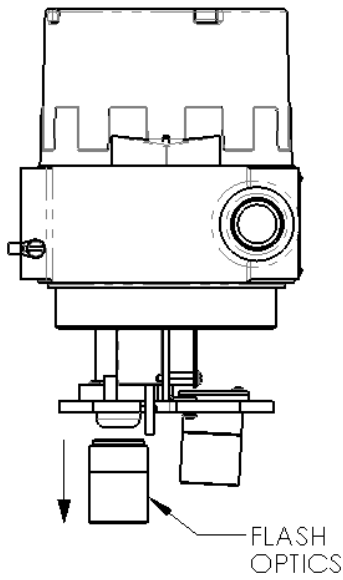

Figure 2  
Flash Optics Replacement

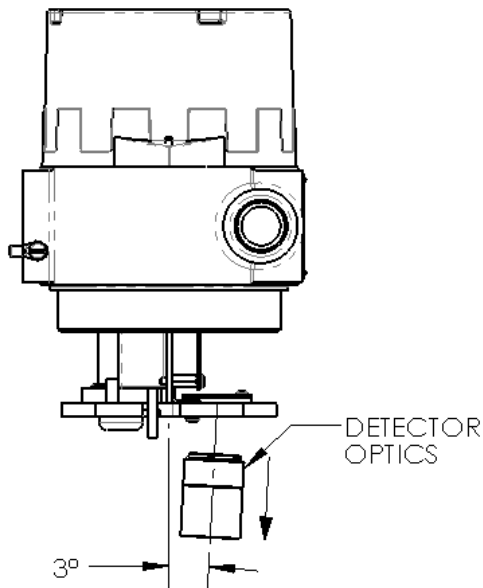

Figure 3  
Detector Optics Replacement

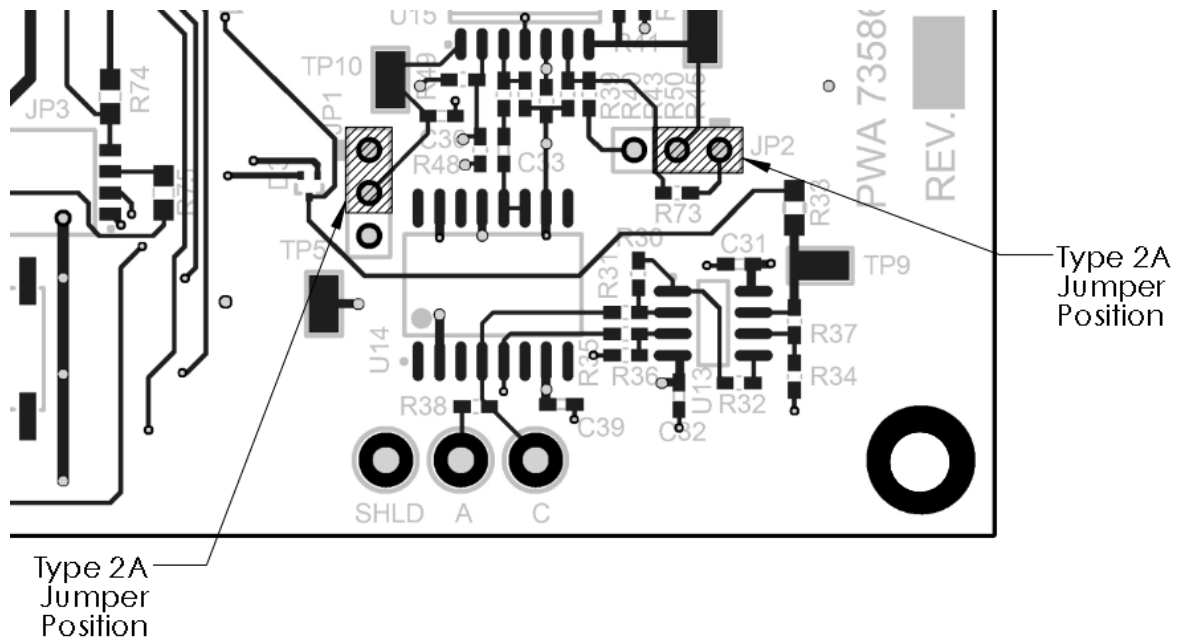

Figure 4A  
Type 2A Jumper Position

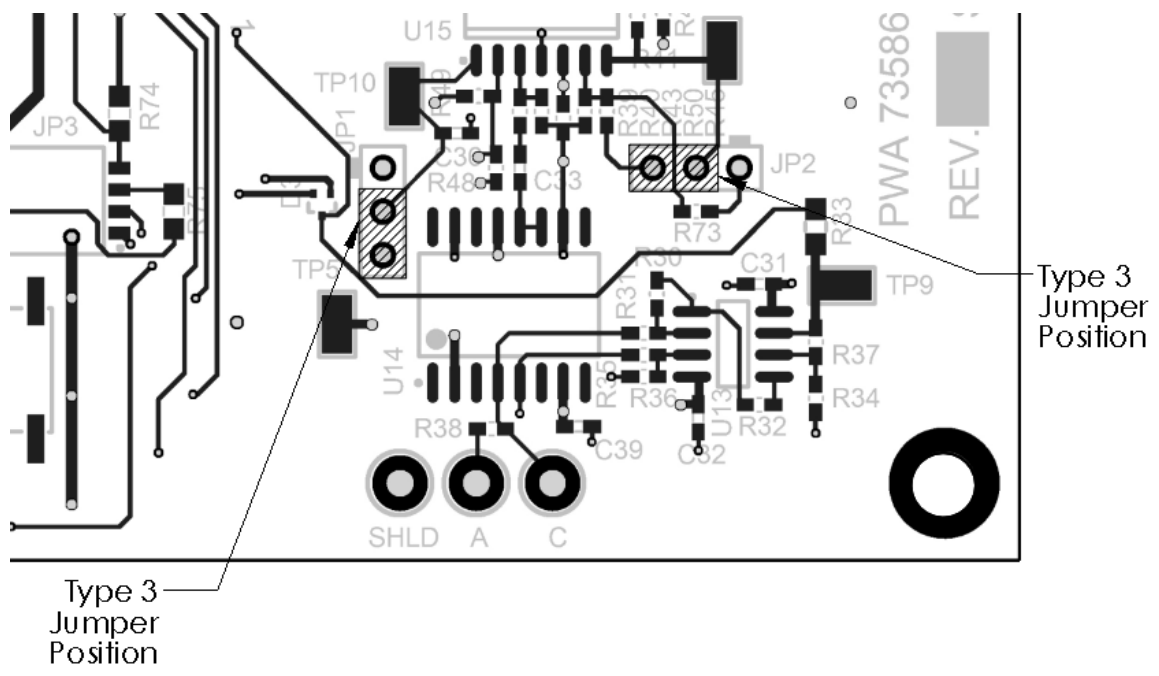

Figure 4B  
Type 3 Jumper Position

**APPENDIX A**

**SLICK SLEUTH UTILITY PROGRAM**

**APPLICATION NOTES**  
**SLICK SLEUTH UTILITY PROGRAM**  
**Version 1.45      September, 2013**

## SOFTWARE INSTALLATION

Operating System: Microsoft Windows 98, 2000, XP, Vista, 7, 8.

Place the program CD in the PC's CD drive.

Click on My Computer and go to the CD drive.

Launch setup.exe and follow the on-screen instructions.

## HARDWARE INSTALLATION

The connection to the Slick Sleuth must be done through a cable as described in Appendix C of the Technical Manual.

If the Slick Sleuth has been setup at a different baudrate than the 9600-baud default, click on the appropriate baudrate in the User Baudrate box.

Click on the COM port to be used in the Comm Port box. If the port is not available (in use by another application or is not present), the program will alert the user.

## BEFORE PROCEEDING

Read all instructions in this file before sending commands to the Slick Sleuth. It is also highly recommended that the Quick Start guide be reviewed as it may contain more current information on the operation of the Slick Sleuth.

## BAUDRATE

The default baudrate of the Slick Sleuth is 9600 baud. The Utility Program always starts with this as its baudrate. If the Slick Sleuth has been set to a different baudrate, it will not respond to commands from the Utility Program (as evidenced by the message "Time Out>>" in the Message Received box). To determine the proper baudrate select "19200", then re-send the command. If the Slick Sleuth does not respond (i.e. "Time Out>>"), change the baudrate to another value and repeat this process until the Slick Sleuth responds.

## SENDING COMMANDS

Before commands can be sent to the Slick Sleuth, the address of the Slick Sleuth must be entered in the Address box. Typically, every Slick Sleuth has address '00' (a Slick Sleuth in a polled system would be the exception). To change the address, always type a two-digit address in the Address box.

### NOTE

It is advisable to set the Slick Sleuth mode to 0 (polled) before sending other commands to the Slick Sleuth. Follow the instructions in Steps 6-7 of the Quick Start to set the mode and then restore the factory setup when done.

To send a command follow these steps:

1. Click on the command to be sent.
2. If the command can send a setting to the Slick Sleuth, a box will open requesting the value and providing guidance on the range and format of the value.
3. If the user only wishes to read the setting from the Slick Sleuth, no value is entered and the 'OK' button is clicked.
4. If the user wishes to send a new setting to the Slick Sleuth, a new value is entered and the 'OK' button is clicked.

#### NOTE

If the user chooses to select another command rather than send the selected command, he may simply click on the new command. If the user chooses to change the selected command (e.g. change a mistakenly entered value), click on the "Reset" button and re-enter the command.

5. Click on the SEND COMMAND button.
6. Observe the response from the Slick Sleuth in the Message Received box.

Examples:

- A. Read the Offset from the Slick Sleuth:
  1. Click on the 'T' command
  2. A box opens requesting the value. Click on 'OK' without entering a value.
  3. Click on the SEND COMMAND button.
  4. The Slick Sleuth responds in the Message Received box. The number after the 'T' in the response is the offset value.
- B. Send a new Offset to the Slick Sleuth:
  1. Click on the 'T' command
  2. A box opens requesting the value. Enter the new Offset and click on 'OK'.
  3. Click on the SEND COMMAND button.
  4. The Slick Sleuth responds in the Message Received box. The number after the 'T' in the response should be the same as the number sent (if the Slick Sleuth accepted the change).

The B, C, and P commands control the measurement timing of the Slick Sleuth. If any one command is entered with a value that conflicts with the other two, the Utility Program will prevent the change and prompt the user to enter an acceptable value. To ensure proper performance, verify that the settings meet the criterion of this equation:

$$P > (( B * C ) / 5) + 2$$

Example:

Flash count = 10  
Flash interval = 01  
Period = 0015

$$(( 10 * 1 ) / 5) + 2 = 4$$

Since  $15 > 4$  the setup is a valid setup.

If the period (P) is set less than 0005, the above criterion does not apply as B and C values are not used by the Slick Sleuth in the fast, single sample mode.

## COMMAND SUMMARY

<u>Command</u>	<u>Description</u>	<u>Range</u>												
A	Address - set or read Slick Sleuth address	00 - 99												
B	Flash Count - set or read number of flashes/sample	01 - 10												
C	Flash Interval - set or read interval between flashes (100 msec/unit)	01 - 99												
D	Detection Request - command the Slick Sleuth to take an immediate sample													
E	Request Data - request report of last sample taken (generally following the 'D' command)													
H	EMI Offset – set or read EMI Offset Correction	0000 - 9999												
I	Set Baseline - command Slick Sleuth to take an immediate sample to establish the baseline													
J	Report Baseline - request report of the baseline measurement (generally following the I command)													
L	Set Mode - set or read the operating mode. The mode identification is provided in the table below. 0 - polled 1 - autonomous, with or without relay output only (no current loop) 4 - autonomous, current loop discrete output 5 - autonomous, current loop scaled output 6 - autonomous, current loop scaled and corrected output													
M	Enable Adaptive Baseline - disable adaptive baseline or set the time span (min.)	00 (disable) - 99												
P	Autonomous Mode Period - set or read the period for autonomous mode sampling (sec)	0000 - 9999												
S	Request Status - request an immediate status measurement and report. The status word includes the mode identification. The status word representing a healthy Slick Sleuth is listed in the table below for each mode.													
	<table border="1"> <thead> <tr> <th>Mode</th> <th>'Healthy' Status Word</th> </tr> </thead> <tbody> <tr> <td>0</td> <td>0000</td> </tr> <tr> <td>1</td> <td>2000</td> </tr> <tr> <td>4</td> <td>8000</td> </tr> <tr> <td>5</td> <td>A000</td> </tr> <tr> <td>6</td> <td>C000</td> </tr> </tbody> </table>	Mode	'Healthy' Status Word	0	0000	1	2000	4	8000	5	A000	6	C000	
Mode	'Healthy' Status Word													
0	0000													
1	2000													
4	8000													
5	A000													
6	C000													
T	Send Offset - set or read the offset used for the detection threshold	0001 - 9999												
V	Request Temperature - request report of internal temperature (deg. C)													
Y	Flash Threshold – set or read Flash Threshold	0000 - 0999												
d	Detection Probability Percentage – set or read Detection Probability Percentage	0,25,50,75,100												
e	Detection Probability Sample Size (# of samples) – set or read Detection Probability Sample Size	4,8,12,....,96												

## USER ASSISTANCE

If assistance is needed in the use of the Utility Program or in the operation of the Slick Sleuth, contact InterOcean Systems at: 858-565-8400 Phone (U.S) or [sales@interoceansystems.com](mailto:sales@interoceansystems.com)

**APPENDIX B**  
**THEORY OF OPERATION**

The Oil Spill Monitor is a remote sensing device for the detection of oil pollution on any surface, most commonly a water surface. It detects oil by stimulating fluorescence in the oil and then detecting the fluorescence. A short burst of collimated UV light is directed onto the surface. The resulting fluorescence is filtered and detected by a focused optical system.

The detected fluorescence is digitized by a 10-bit A/D. The fluorescence level for each flash within a sample (typically 10 flashes) are averaged together to reduce noise and improve signal integrity. The result is an integer number in the range of 0 – 1,023 “counts” (engineering units).

The signal measured by the A/D has several components. Figure B-1 illustrates the components. Starting at the bottom of the figure, the Oil Spill Monitor has some inherent self-noise, typically on the order of 25 counts. The self-noise count is subtracted from all measurements before the measurement counts are reported and/or used for detection and output.

The ambient condition, which can consist of several things but is predominantly unwanted reflection from a water surface, adds to the measurement. When a “baseline” measurement is performed, the level that is recorded and used as a part of a detection algorithm is the level of the ambient condition. Added above the ambient condition (baseline) is the fluorescence from any oil detected.

For purposes of discrete detection (i.e. discrete current loop output, relay, or “Y/N” digital output) a “detection threshold” is established. This is accomplished by inputting an “offset”, a variable that the operator uses to establish the detection threshold and thereby the detector sensitivity. Any count value above the detection threshold is a detection. Mathematically the detection threshold is expressed as:

$$\text{Detection Threshold} = \text{Baseline} + \text{Offset}$$

The current loop output has one or more corrections applied to it, dependent on operating mode. In Scaled Output (mode 5) the self-noise is subtracted from the measured counts and then converted to current output. In this case 4 ma out represents the level of the self-noise (25 counts typ in Figure B-1). Full scale output is 1,023 counts minus the self-noise. In Figure B-1 full scale would be  $1,023 - 25 = 998$  counts. In order to maintain a constant relationship between counts (and current output) signal strength, the full-scale count for 20 ma output is fixed at 1,023 counts. The result is that full scale output in this mode is slightly less than 20 ma. In the figure the full scale would be:

$$\begin{aligned} \text{Full Scale Output} &= 4 + (998/1,023) * 16 \text{ ma} \\ &= 19.61 \text{ ma} \end{aligned}$$

In Scaled/Corrected Output (mode 6) both the self-noise and the baseline are subtracted from the measured counts and then converted to current output. In this case 4 ma out represents the baseline level (50 counts typ in Figure B-1) plus the self-noise (25 counts typ in Figure B-1). Full scale output is 1,023 counts minus the baseline and the self-noise. In Figure B-1 full scale would be  $1,023 - 50 - 25 = 948$  counts. As in Scaled Output, the full-scale count for 20 ma output is fixed at 1,023 counts. The result is that full scale output in this mode is less than 20 ma. In the figure the full-scale output would be:

$$\begin{aligned} \text{Full Scale Output} &= 4 + (948/1,023) * 16 \text{ ma} \\ &= 18.83 \text{ ma} \end{aligned}$$

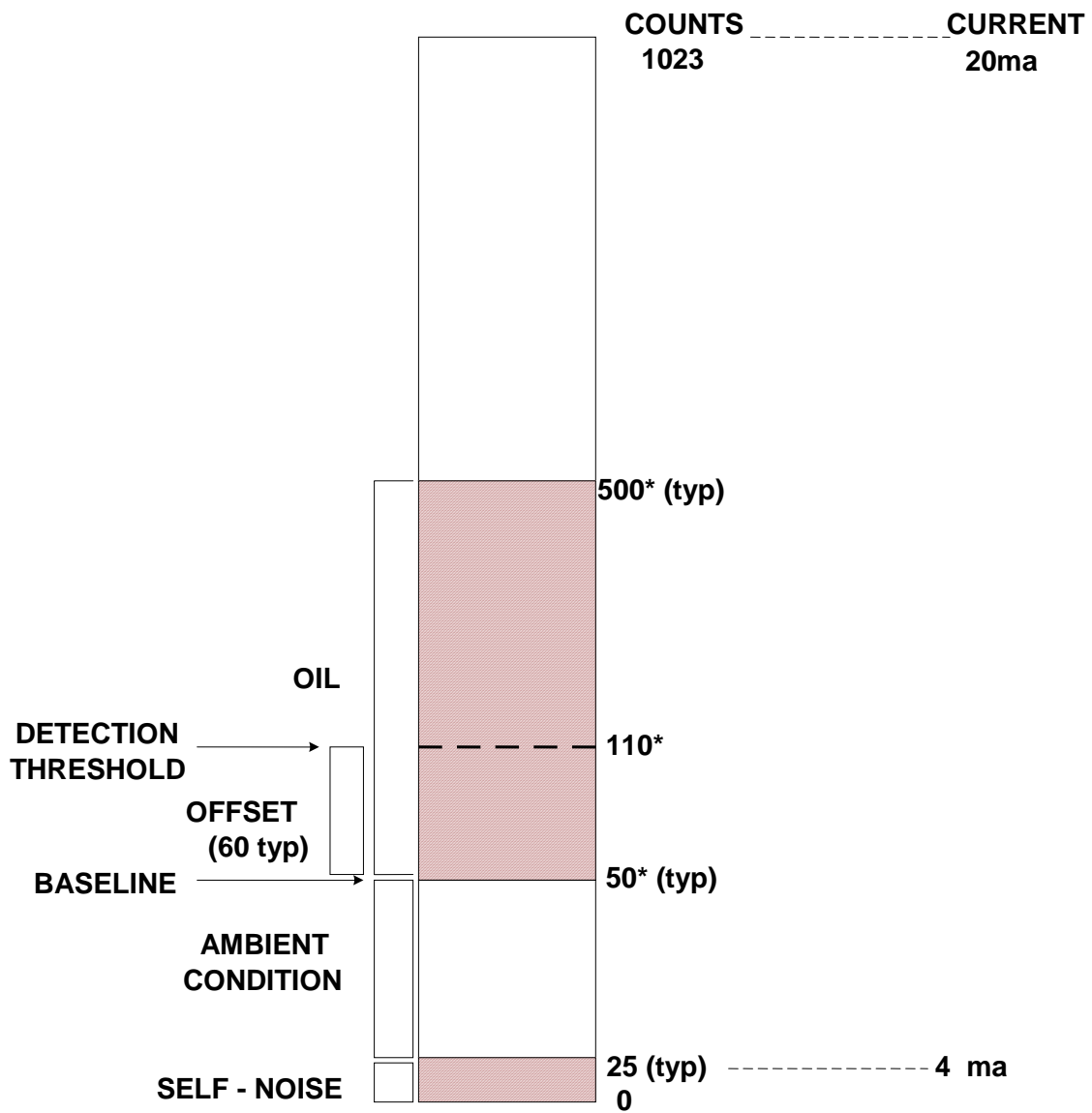

Figure B-1

Detection Output

\*counts after self-noise has been subtracted

**APPENDIX C**

**EXTERNAL  
SERIAL COMMUNICATIONS INTERFACE**

The external serial communications interface is a USB port which communicates through a virtual COM port on a PC. It is typically configured for 9600 baud, 8 bit, 1 stop bit, no parity. The baudrate is programmable and may be set during production as specified by the purchase order. If the baudrate is not specified by the purchase order, the baudrate is set at the default value of 9600 baud.

The interconnection between the OSM and the PC is a 5-pin micro USB connector located under the top glass cover. A mating cable, IOS P/N 940012522, is provided to make this interconnection.

**APPENDIX D**  
**SERIAL COMMUNICATIONS PROTOCOL**  
**SLICK SLEUTH**

## **SERIAL COMMUNICATIONS PROTOCOL SLICK SLEUTH**

### **A. SERIAL COMMUNICATION**

For local access, typically for initial setup or periodic maintenance, a USB port is provided under the top cover of the enclosure. The port provides the user with two capabilities: 1) The ability to change setup parameters and obtain a status report on the health of the Station, and 2) access to the periodic detection report in digital format.

### **B. OIL SPILL MONITOR FACTORY SETUP**

During factory setup the Oil Spill Monitor accepts simple setup commands for test and configuration. The Oil Spill Monitor replies with an acknowledgement.

### **C. FIELD SETUP**

Each Oil Spill Monitor may be setup in the field as required. Typically, all setup (excluding baseline) is done at the Factory prior to shipment and no further setup is required. Baseline measurement must be done at installation to ensure that the detection threshold is set properly.

## COMMAND SUMMARY

COMMAND BYTE	TYPE	OIL SPILL MONITOR RESPONSE	CENTRAL MONITOR/FACTORY SETUP FUNCTION
A	Command	Echo command and address	Normally factory setup; default address is '00', Oil Spill Monitor accepts 'A' command only if current address is default
B	Command	Echo command and count	Send/request flash count
C	Command	Echo command and interval	Send/request flash interval
D	Command	Echo command	Send request to make reading
E	Status	Report last reading	Send request for last reading
H	Command	Echo command and EMI Offset	Send/request EMI offset
I	Command	Auto baseline measurement and report	Send request for baseline measurement
J	Command	Report baseline value	Send request for current baseline value
K	Command	Echo command and S/N	Send/request Oil Spill Monitor S/N
L	Command	Echo command and mode	Normally factory setup; set/request operating mode
M	Command	Echo command and Adaptive Baseline	Send/request Adaptive Baseline setting
P	Command	Echo command and sample period	Send/request autonomous mode sample period
S	Status Request	Send self-test status to Central Monitor	Periodic request for status
T	Command	Echo command and offset	Send/request offset
V	Command	Report Internal Temperature	Send/request for internal temperature
Y	Command	Echo command and Flash Threshold	Send/request Flash Threshold

<b>Z</b>	<b>Command</b>	<b>Echo command and baudrate</b>	<b>Set baudrate</b>
<b>d</b>	<b>Command</b>	<b>Echo command and Detection Threshold Percent</b>	<b>Send/request Detection Probability Percent</b>
<b>e</b>	<b>Command</b>	<b>Echo command and Detection Window Size</b>	<b>Send/request Detection Probability Sample size</b>

The typical response from an OSM in the 'Message Received' window of the Utility Program has this form for reference:

AA C XXXX M@

Where:

AA – unit address (typically '00')  
C – An echo of the command character sent to the OSM  
XXXX – the data requested by the command  
M@ - checksum and end character

The Request Data and Status commands have a response in this form:

AA C X XXXX Y SSSS M@

Where:

SSSS – status word  
Y (or N) – detect or no detect (N)

## STATUS REPORT

Equipment status is reported as a four ASCII character representation of a two-byte hex-encoded self-test status word. The bits of the status word are encoded as follows:

BIT	NIBBLE	LABEL	FUNCTION
0	4		Reserved
1			Reserved
2		+12V LO	Regulated +12V supply below min.
3		-12V LO	Regulated -12V supply below min.
4	3		Reserved
5		FLASH SIG LO	Flash light output below min.
6			Reserved
7			Reserved
8	2	OVERTEMP	Internal temperature above specified max.
9		UNDERTEMP	Internal temperature below specified min.
10		BKGND HI	High ambient light detected, may cause detector sensitivity loss
11			Reserved
12	1		Reserved
13		MODE0	Three-bit representation of autonomous operating mode:
14		MODE1	MODE            MODE2            MODE1            MODE0
15		MODE2	4-20 discrete            1            0            0 4-20 scaled            1            0            1 4-20 scaled/corrected            1            1            0

When any one of bits 0-12 is set, it indicates that a fault has occurred. Bits 13-15 are a 3-bit encoded representation of the operating mode of the Oil Spill Monitor.

When status is reported by the Oil Spill Monitor it is reported in the following format:

(Nibble 1) (Nibble 2) (Nibble 3) (Nibble 4)

Normal (healthy) operational status is reported as 8000 in the 4-20 discrete output mode, A000 in the 4-20 scaled output mode, and C000 in the 4-20 scaled/corrected output mode.

## Hexadecimal to Binary Conversion Table

Status Digit (Hexadecimal)	Binary
0	0000
1	0001
2	0010
3	0011
4	0100
5	0101
6	0110
7	0111
8	1000
9	1001
A	1010
B	1011
C	1100
D	1101
E	1110
F	1111

**APPENDIX E**

**PREVENTATIVE MAINTENANCE**

**Preventative Maintenance (PM)  
Slick Sleuth Oil Spill Monitor**

**Every 30 Days, 60 Days, or As Required PM. See attached check list for example.**

- 1) Conduct a thorough physical inspection of the Oil Spill Monitor.

Check the optics for obstructions; i.e. spider webs, salt, water spots, or foreign film. *If necessary* clean optical glass using the following procedure:

- i. Use compressed dry air and/or distilled water to flush away any film or debris build-up on the surface of the glass window.
  - ii. **Caution:** when examining the glass surface on the underside of the sensor it is recommended that the unit be stopped (mode 0) to avoid extended direct eye exposure to UV light.
  - iii. If dirt or impediment is still present after rinsing with distilled water, use lens tissue or a soft clean cloth to wipe away and clean optical glass surfaces. Commercial glass cleaner may be used if necessary to remove difficult dirt.
  - iv. Use caution not to scratch optical glass.
  - v. Use caution so that no oil or fingerprints are left on the optical glass surface.
  - vi. Return unit to normal operating mode and setup parameters.  
(Section 3.2 of the manual covers this procedure).
- 2) Inspect the sample area (water/ground) directly beneath the sensor for any obstructions, contaminants, and abnormalities. Observe area both above, on and below the water line.
- 3) Periodic field assurance test may also be conducted. At a fixed distance (for example ½ meter below sensor) place a sample of oil. If using oil is not an option, a sheet of white paper can be used to simulate oil, or material smeared with oil. For consistency the same type(s) and amount(s) of oil or 'oil simulating' material should be used to test alarm. Place oil beneath the sensor and confirm that local alarm activates, as well as in control room or wherever remote oil alarm output is monitored. Likewise confirm that PLC / externally activated devices such as pumps, valves, skimmers activate accordingly.
- 4) If any settings are changed using the Utility Program, record changes in instrument record and/or on check list. To check existing settings, select any command (i.e. Offset "T" command). Enter no value (leave blank), click OK, and then Send Command. Existing value is reported in message received window.

**Every 6-Month, 1-Year, or As Required PM. See attached check list example.**

- 5) Conduct thorough physical inspection described in item 1 above. Additionally:
- 6) Put the unit into mode 0 and power off prior to interior inspection and cleaning.
- 7) Inspect the conduit fittings to ensure they are secure.
- 8) Inspect each cover seals. Check for cracking, tearing, and for proper seal.
- 9) Inspect enclosure interior for debris (wire strands, loose hardware, etc) and remove as necessary. If dust build-up is present, carefully vacuum interior and/or blow out enclosure using compressed dry air.
- 10) Clean the enclosure of all debris and particulate matter. Take care not to spray cleaner inside optical tubes.
- 11) Clean the window as described in Step 1. Replace desiccant packs (if installed) as described in Section 4.1.1 on the IO&M Manual.
- 12) Perform diagnostic check:
  - a. Connect portable computer to the unit.
  - b. Using SS Utility Program, put unit into mode 0 (“L” command).
  - c. Issue a Status Request command (“S” command).  
The result of a fully functional unit should be 0000. See Figure 1 for Example.  
(If using SS Utility Program Rev 1.45 or later, all indicators should be green)
  - d. If a number other than 0000 is present (if diagnostic fault is detected); consult the Status Report table in Appendix D (Operations Manual).
  - e. Troubleshooting is covered in Section 4.3 of the manual.
  - f. For further assistance contact InterOcean Systems: tel.858.565.8400 USA.
- 13) Issue a “Debug” (1) command to check the flash count.
  - a. This procedure is located in Appendix F.
  - b. Flash count numbers will be the last 10 numbers in column 4 of the large window on the main screen. The flash count appears below this column. See Figure 2 for Example.
  - c. Calculate a new flash threshold value that is 60% of the flash count number observed in Step b. Enter the new value into the OSM by performing the following steps using the Utility Program:
    1. Go to the Real Time Logging window, select ‘Factory Setup’, then enter the factory password.
    2. Return to the main window.
    3. CLEAR the Commands list.
    4. Select ‘Flash Threshold (Y)’.
    5. When the data entry window appears enter the 60% value calculated as the new flash threshold value. Select ‘OK’
    6. SEND the new value to the Slick Sleuth

EXAMPLE:

The flash count number observed in Step b. is 676. Calculate the new flash threshold value:

$$\text{Flash Threshold Value} = 60\% * 676 = 405$$

This new value would be entered into the Slick Sleuth using the command sequence in Step c. The value would be entered as '0405'.

- 14) The anticipated flash lamp life is approximately 2½ - 3 years at the highest sampling rate. The fault alarm will alert the user to lamp failure. The lamp can be replaced at that time or can be treated as a periodic / preventative maintenance item and replaced on a cyclical schedule. Note that if lamp failure is suspected, the first course of action is to perform items 12 and 13 above. If lamp replacement is necessary (either failure or as PM), please refer to Section 4.2 for lamp replacement procedure. This will also direct you to Appendix F for completing the replacement process.

**Figure 1** (on right)  
#1 Status 0000 (in Message Received window). No faults  
#2 Status Green Light.  
No fault.

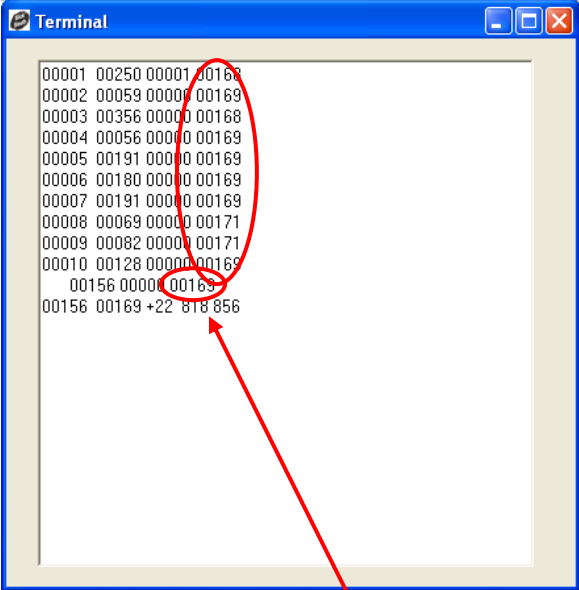
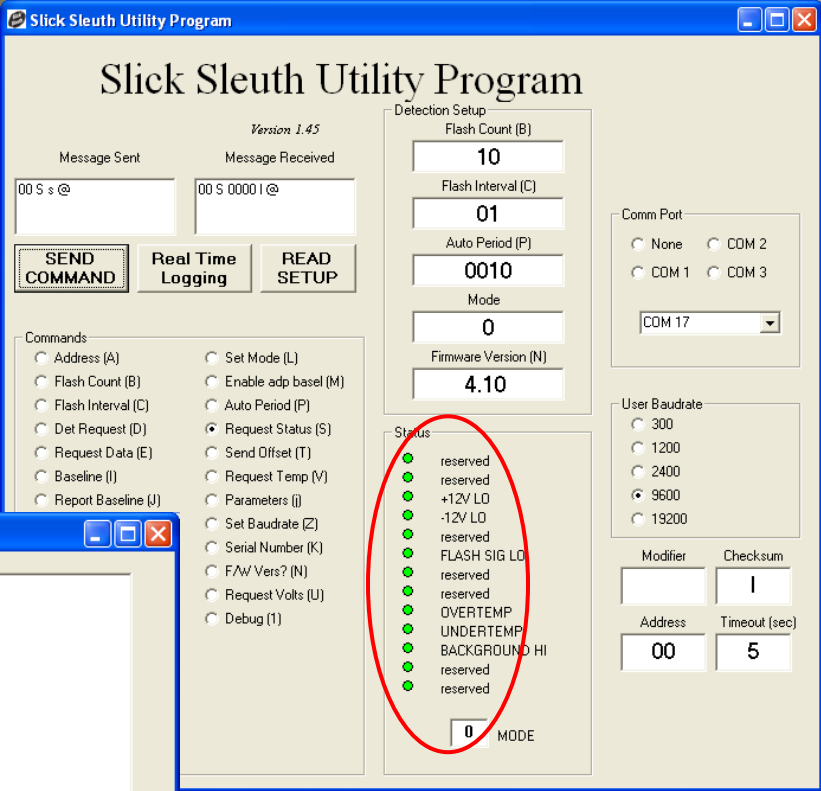

**Figure 2** (on left)  
#3) Debug command sent & received. All values within ± 10%.  
Sensor/flash healthy.

Flash Detection Count



**PREVENTATIVE MAINTENANCE  
SS100 CHECK LIST**

Name:	<input type="text"/>
Date:	<input type="text"/>

<input checked="" type="checkbox"/>	Comments
-------------------------------------	----------

**Preventative Maintenance - Monthly**

1 Physical Inspection	<input type="checkbox"/>	<input type="text"/>
2 Inspect Sample Area	<input type="checkbox"/>	<input type="text"/>
3 Inspect Accessories	<input type="checkbox"/>	<input type="text"/>
4 Field Assurance Test (Optional)	<input type="checkbox"/>	<input type="text"/>
5 Settings - Utility Program (Optional)	<input type="checkbox"/>	<input type="text"/>

**Preventative Maintenance - Semiannually or Annually**

6 Physical Inspection / Items 1 - 5	<input type="checkbox"/>	<input type="text"/>
7 Set Mode to "0"	<input type="checkbox"/>	<input type="text"/>
8 Inspect - Cable Glands	<input type="checkbox"/>	<input type="text"/>
9 Inspect - Cover Seals	<input type="checkbox"/>	<input type="text"/>
10 Inspect - Enclosure	<input type="checkbox"/>	<input type="text"/>
11 Clean Window	<input type="checkbox"/>	<input type="text"/>
12 Clean Enclosure & Accessories	<input type="checkbox"/>	<input type="text"/>
13 Diagnostic Check	<input type="checkbox"/>	<input type="text"/>
14 Flash Count Check	<input type="checkbox"/>	<input type="text"/>
15 Flash Lamp Check	<input type="checkbox"/>	<input type="text"/>
16 Return to Normal Operating Mode	<input type="checkbox"/>	<input type="text"/>

**Saved Configuration**

		Record Value
S Request Status	(i.e. 0000)	<input type="text"/>
J Report Baseline	(i.e. 50)	<input type="text"/>
T Send Offset	(i.e. 60)	<input type="text"/>
L Set Mode	(i.e. 4)	<input type="text"/>
P Autom ous Mode Period	(i.e. 0005 = 5 sec)	<input type="text"/>
M Enable Adaptive Baseline	( i.e. 00 Disabled / XX Enabled)	<input type="text"/>
B Flash Count	(i.e. 10)	<input type="text"/>
C Flash Interval	(i.e. 01 = 1 m sec)	<input type="text"/>

## **APPENDIX F**

# **SLICK SLEUTH LAMP REPLACEMENT INSTRUCTIONS**

# SLICK SLEUTH LAMP REPLACEMENT INSTRUCTIONS

## References

Dwg. No. 735861164      Slick Sleuth OSM Quick Start Instructions  
P/N 73586600103      Slick Sleuth Utility Program, V1.46

## Procedure

### NOTE

The following procedures have been developed based on use of the Utility Program.

- 1.1 Disconnect power to the Oil Spill Monitor.
- 1.2 Remove the cover on the bottom of the enclosure.
- 1.3 Locate the flash optics assembly as shown in Figure 1.
- 1.4 Remove the flash optics assembly by unscrewing it from the mounting plate.
- 1.5 Remove the flash lamp by pulling it downward, away from the trigger socket. Do not twist the flash lamp.
- 1.6 Plug the replacement flash lamp into the trigger socket. Wear cotton gloves or similar handling materials to avoid leaving finger oil or other dirt or residue on the flash lamp.

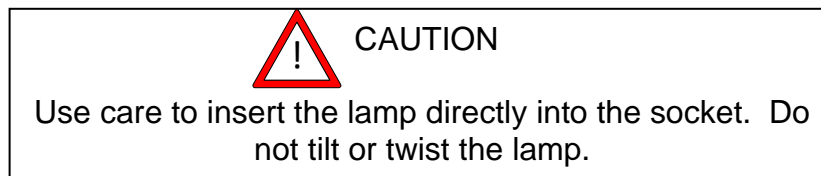

- 1.7 Re-assembly is completed in reverse order.
- 1.8 After a flash lamp is replaced an initialization measurement must be done (See Section 2.4 Initialization). Flash lamps vary in performance, so it is critical that the Oil Spill Monitor be initialized to achieve good performance.
- 2.1 Cover each optics hole with opaque black electrical tape. Do not let the tape touch the surface of the optics.
- 2.2 Establish serial communications with the OSM using Step 2 in the Advanced Setup section of the Quick Start Instructions.

- 2.3 If the 'L' command returned a number other than 0, it is necessary to change the mode to facilitate this procedure. Write down the number returned in the 'L' command for re-initialization after completion of this procedure, then proceed with the following steps:
  1. Select the 'L' command and enter 0 when asked to enter the mode. Select 'OK'.
  2. Click on the SEND COMMAND button.
  3. Observe that the OSM responds with 00 L 0 k @ or a similar response.
- 2.4 Click on the REAL TIME LOGGING button.
- 2.5 In the Real Time Logging window click on the Factory Setup button and enter the password '73586'.
- 2.6 Return to the main window.
- 2.7 Select the 'H' command and enter 0000 when asked to enter the EMI Offset. Click on the SEND COMMAND button.
- 2.8 Select the 'D' command. Click on the SEND COMMAND button. Wait for the unit to stop flashing before sending the next command.
- 2.9 Select the 'E' command. Click on the SEND COMMAND button.
- 2.10 The 5-digit number reported is the measured EMI offset. Record for reference.
- 2.11 Select the 'H' command and enter the number recorded in Step 2.10 when asked to enter the EMI Offset. Click on the SEND COMMAND button.

#### NOTE

The entered number must be 4 digits in length. For example, if the measured and reported EMI Offset was '00023', enter '0023'.

- 2.12 Remove the black electrical tape from the optics holes.
- 3.1 Select the '1' (Debug) command. Click on the SEND COMMAND button.
- 3.2 Wait approximately 30 seconds for the unit to complete its full self-diagnostics test. The response will appear in the large text box.
- 3.3 Locate the number (the flash detection counts) under the fourth column (just above the last row). See Figure 2.
- 3.4 Calculate a number that is 60% of the number read in Step 3.3. Round the number down to a whole integer. Example: the number read in Step 3.3 is 676. Calculating the value,  $60\% * 676 = 405.6$ . Rounding down, the number becomes 405.

- 3.5 Using the utility program, perform the following steps:
- 3.5.1 Go to the Real Time Logging window and select 'Factory Setup'. Enter the password '73586'.
  - 3.5.2 In the main window select 'Flash Threshold (Y)'.
  - 3.5.3 When the data entry window appears enter the value calculated in Step 3.4, then click on 'OK'. For the example in Step 3.4, the value entered would be '0405'.
  - 3.5.4 SEND the new value to the OSM.
- 4.1 Select the 'L' command and enter the number recorded in Step 2.3 to restore the normal operating mode.
- 4.2 Click on the SEND COMMAND button.
- 4.3 Observe that the OSM responds with 00 L X a @, and that the OSM returns to its normal operating mode. X is the number you entered for the mode. The '00' and the checksum may be different than written here.

PROCEDURE COMPLETE

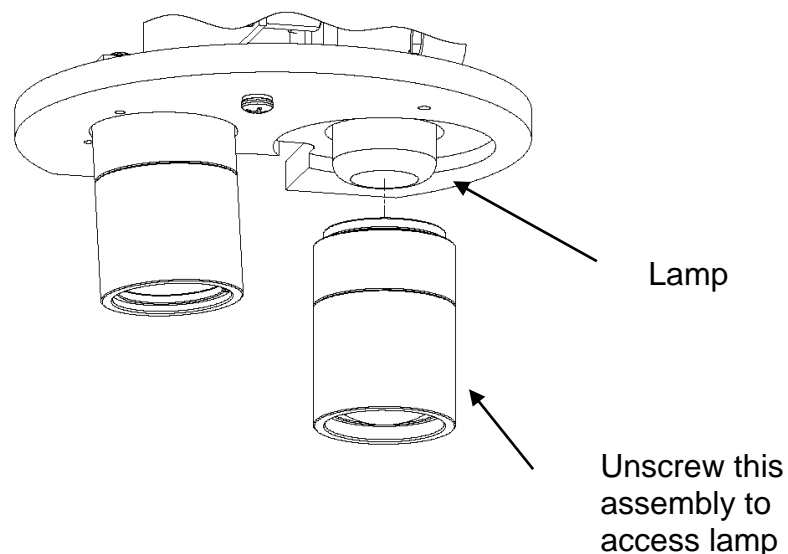

Figure 1  
Flash Lamp

```
Terminal
00001 00250 00001 00168
00002 00059 00000 00169
00003 00356 00000 00168
00004 00056 00000 00169
00005 00191 00000 00169
00006 00180 00000 00169
00007 00191 00000 00169
00008 00069 00000 00171
00009 00082 00000 00171
00010 00128 00000 00169
00156 00000 00169
00156 00169 +22 818 856
```

Flash Detection Count

Figure 2

**APPENDIX G**

**USB DRIVER INSTALLATION**

## INTRODUCTION

The USB port on the Oil Spill Monitor requires drivers to be installed on the connected PC. Generally, the drivers supplied by Microsoft are suitable, but depending on the operating system (OS) and the hardware platform the drivers may not perform properly. In this case drivers must be downloaded from the manufacturer of the USB interface hardware and installed to insure proper performance.

## DRIVER INSTALLATION

1. Connect the PC to the Internet and go to [ftdichip.com](http://ftdichip.com).
2. On the left side of the home window select 'DRIVERS'.
3. Under 'DRIVERS' select 'VCP DRIVERS'.
4. The window that appears is the Virtual COM Port Drivers window. On this window:
  - a. Select 'Installation Guides'. Locate the Installation Guide appropriate to the OS of the PC, download and open it.
  - b. Return to the Virtual COM Port window and select the driver appropriate to the OS and download it.
5. Follow the instructions in the Installation Guide to install the driver.

## **APPENDIX H**

**RS485**

## SCOPE

This Appendix provides information specific to the RS485 port for the Slick Sleuth SS100.

## 2 DESCRIPTION

The RS485 port provides the user with a screw terminal plug that provides a 4-wire RS485 serial connection to the SS100. This connection provides the means for the user to remotely monitor the operation of the SS100 and to perform changes to operating characteristics as required.

## 3 SPECIFICATIONS

### Screw Terminal Plug

Wire Gauge 18 - 26 AWG (stranded)

## 4 INSTALLATION

### 4.1 4-Wire Connection

Field wiring is done using cable with a minimum of 5 conductors conforming to the wire gauge specification. It is recommended that the wire be grouped in two twisted shielded pairs (TSP) plus a minimum of one wire, or that the cable have an overall shield, to minimize the risk of external interference. If TSP cable is used, one pair must be used for transmit (TX) and one pair must be used for receive (RX).

Field wiring is routed through one of the two conduit hubs located adjacent to terminal strip TS1. The screw terminal plug for the RS485 wire termination, TS2, is a small green plug located underneath TS1. The plug may be removed from its mating receptacle to facilitate wiring.

The wire termination is done as shown in Figure 1 below. The terminal numbers for TS2 are marked at the back of the plug receptacle.

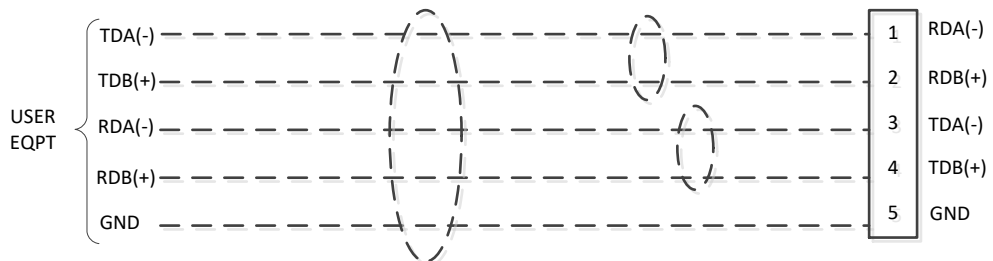

Figure 1

4-Wire RS485 Field Wiring

## 4.2 2-Wire Connection

Field wiring is done using cable with a minimum of 3 conductors conforming to the wire gauge specification. It is recommended that the wire be grouped in one twisted shielded pair (TSP) plus a minimum of one wire, or that the cable have an overall shield, to minimize the risk of external interference.

Field wiring is routed through one of the two conduit hubs located adjacent to terminal strip TS1. The screw terminal plug for the RS485 wire termination, TS2, is a small green plug located underneath TS1. The plug may be removed from its mating receptacle to facilitate wiring.

The wire termination is done as shown in Figure 2 below. The terminal numbers for TS2 are marked at the back of the plug receptacle.

Prior to applying power to the SS100 remove the lower cover and locate switch JP3 on the Controller board. Set switches JP3-1 & JP3-2 to the ON position.

If required by the installation (e.g. if the unit is at the end of a long cable or at the end of a daisy chain of units) the internal termination resistor (121 ohms) may be connected by setting JP3-3 to the ON position.

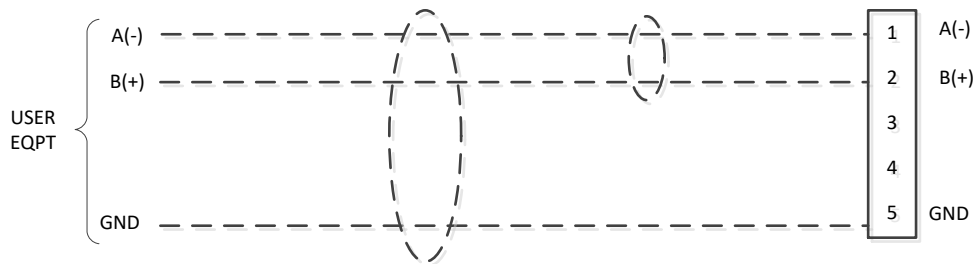

Figure 2

### 2-Wire RS485 Field Wiring

## 5 OPERATION

The RS485 port provides serial communications capabilities equivalent to the function of the USB port at the User Interface. The description of these capabilities is provided in the IO&M Manual, Section 3.2.